

# WHAM

## NEWS, VIEWS and REVIEWS

Issue JE-98  
July 15, 2012

Official Publication of the Wichita Historical Aircraft Modelers, SAM 56,  
and the Kansas Sunflower Squadron, FAC Squadron #23

## Flying Site Status

A lull in the Kansas wind resulted in a plethora of flyers taking advantage of the conditions on Saturday, July 7th. The wind was minimal and light enough to allow flying from the north side of the field. I arrived first, followed by Bill Schmidt, George Avila, Jim O'Reilly, Earl Griffith, and Chuck Powell. Obviously everyone wanted to get some trimming in for the following Saturday contest in Denver.

About a half hour later someone noted a woman yelling from the east road, unfortunately out of hearing range. I thought she might have had a problem, but someone stopped and talked with her and they then left. About 40 minutes later, the time it takes to drive in from Garden City, the gentleman that hay's the field arrived. He is Mrs. Barbor's brother, and apparently our use of the field hasn't really been coordinated well enough within the family. The issue is our driving vehicles and chase bikes strain the grass enough to cause problems with cutting. He requested that we stop it until the haying process is completed for this year. That may occur in time for this weeks fun fly, but don't count on it. George and Bill volunteered to act as contacts to establish when the field is available. So before going out for the rest of the year, check with George (683-1474) to find out if we can enter.

The discussion with the framer was quite lengthy and he did indicate that he really doesn't want us on the field while the grass is growing. He stated that his view of the growing season was March through July. He didn't leave happy, but didn't really run us off the field at that moment. With the mood severely altered, the flying slowed down and most of us had left within 45 minutes.

## March 10, 2012 Meeting Minutes

### **ATTENDEES:**

Mary Kay & George Avila, Paula & Jeff Englert, Regina and Marty Kline, , Jane & Earl Griffith, Marty & Jim O'Reilly, Linda & Chuck Powell, Cindy & Dan Walton

President Avila called the meeting to order.  
The previous meeting minutes were approved.  
The treasurer's report was presented.

### **OLD BUSINESS:**

None.

### **NEW BUSINESS:**

Cancelled due to noise!

### **SHOW AND TELL:**

Jim O'Reilly disp[alyed a class C Challenger thAt he has CAD drawn from the June 1954 Flying Models magazine article. Soon to be a kit.

Chuck Powell had a @x peanut enlargement of a Nesmith Cougar design. He added the Don DeLoach DT mechanism of rotating the stab.

Linda Powell had her Stan Buddenbohn based Scout catapult glider which was recently returned after going OOS from the flying field into Andover, an estimated 6 mile m flight.

Dan Walton showed off hie old Gym Dandy, a Brown CO2 powered ship that was published back in Model Aviation in September 1977.

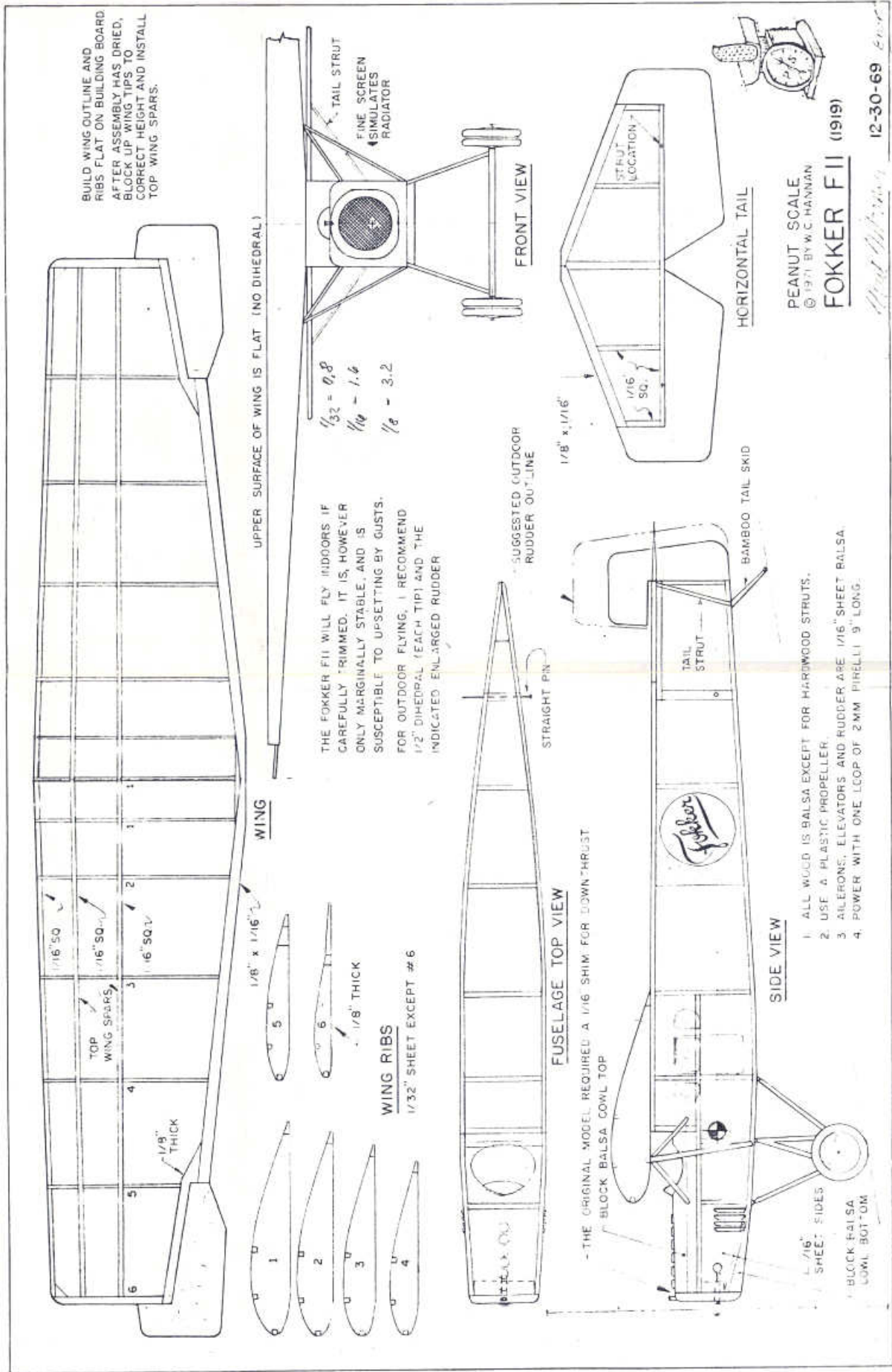

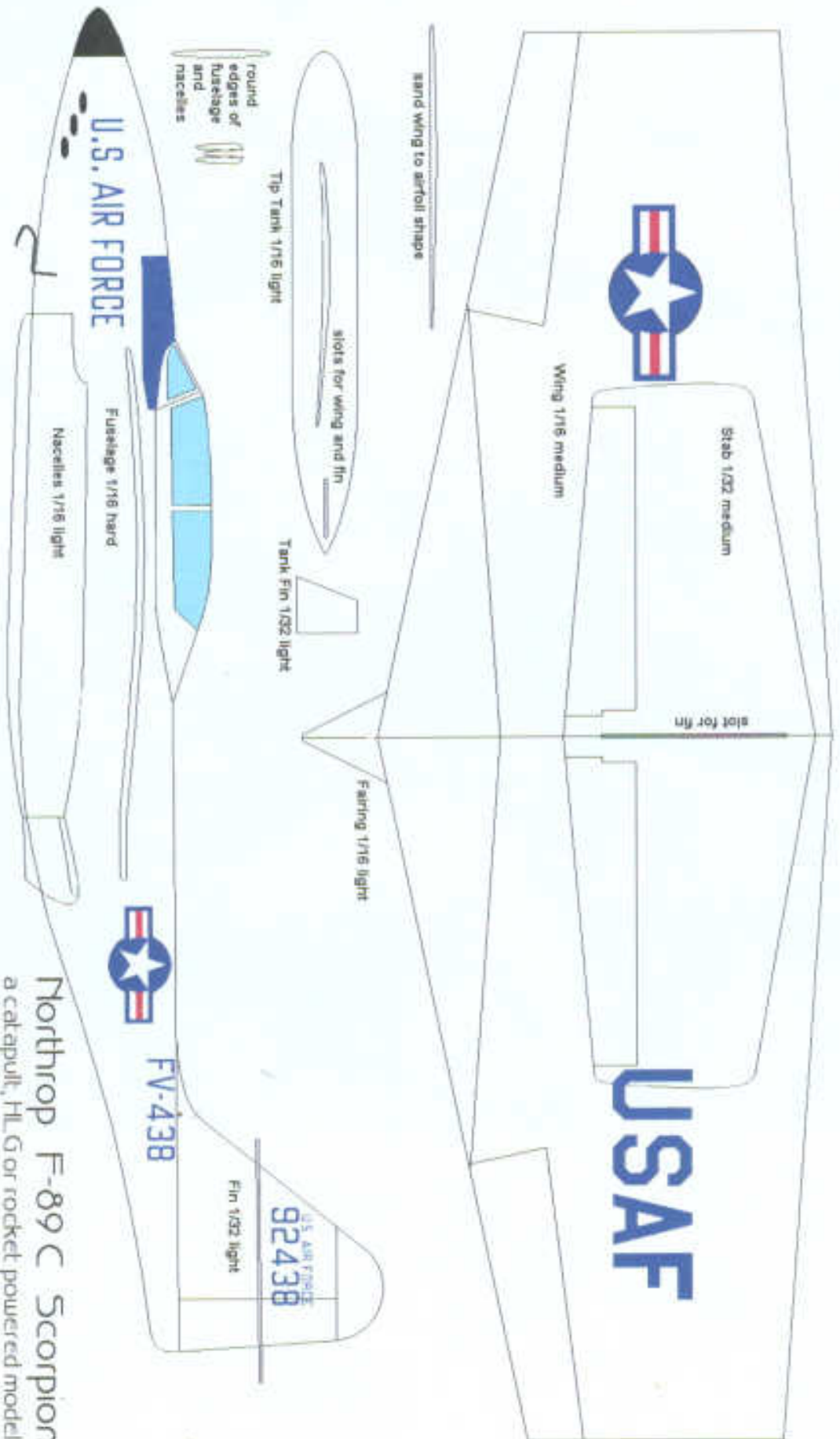

Northrop F-89 C Scorpion  
 a catapult, HL G or rocket powered model  
 By Carlo Godel

(30 AF MUSEUM PAPER ARCHIVES)

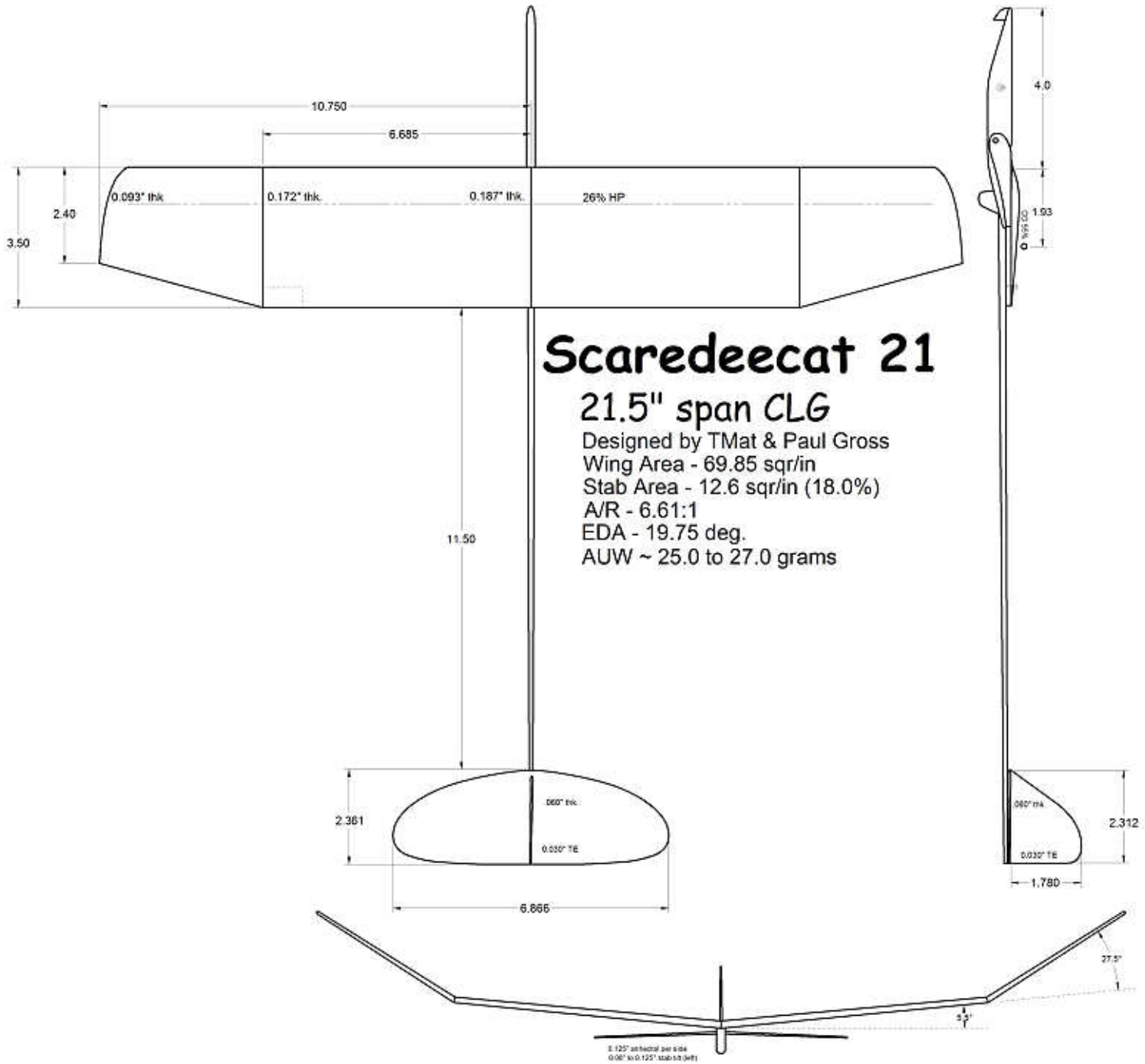

WHAM – News, Views and Reviews  
 Jeff Englert  
 10118 Sterling Court  
 Wichita, KS 67205

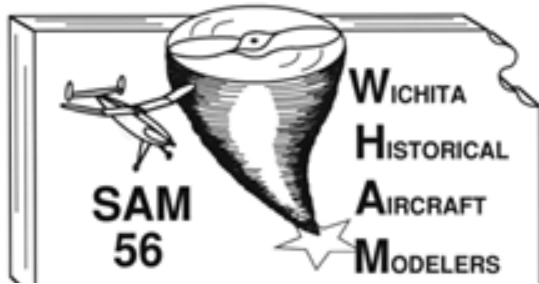

FLYING  
ACES



Sunflower Squadron  
 Wichita, KS

The next SAM 56 Dinner Meeting will be at:

## Louie's Grill & Bar

**9747 E 21st St N, Wichita, KS 67206**

(SE corner of Web and 21st N)

**(316) 636-5422**

**Saturday, July 21, 2012**

Social Hour @ 6:00 PM, Dinner @ 7:00 PM..

### Upcoming events:

July 21/22 Meeting Fun fly, 1/2 A Texaco, small rubber combined (150 in<sup>2</sup>),  
 Cat glider, and 1/2A early NOS

**Aug 18/19 Fun Fly**

**Sep 22/23 Meeting Fun Fly**

### Membership Information:

Open to all interested AMA members, founded to encourage and promote the model airplane building hobby. Member dues \$20 annually, Subscription only; \$12 annually, \$18 foreign.  
 Send checks to Jim O'Reilly, 4760 Battin, Wichita, KS 67220.

All memberships and subscription renewals are due January 1st of the new year.

Club Officers: President: George Avila, 683-1474 Vice-President: Bill Schmidt 744-0378,  
 Treasurer: Jim O'Reilly, 744-0856 Secretary: Jeff Englert, 722-7491