

S.A.M. Chapter 13  
AMA Charter #158



**Official Newsletter of the Southern California Antique Model Plane Society**

**Founded in 1964**

*Website address: <http://SCAMPS.homestead.com>*

Return Address:  
Lance Powers  
1207 Trinidad Circle  
Placentia, CA 92870

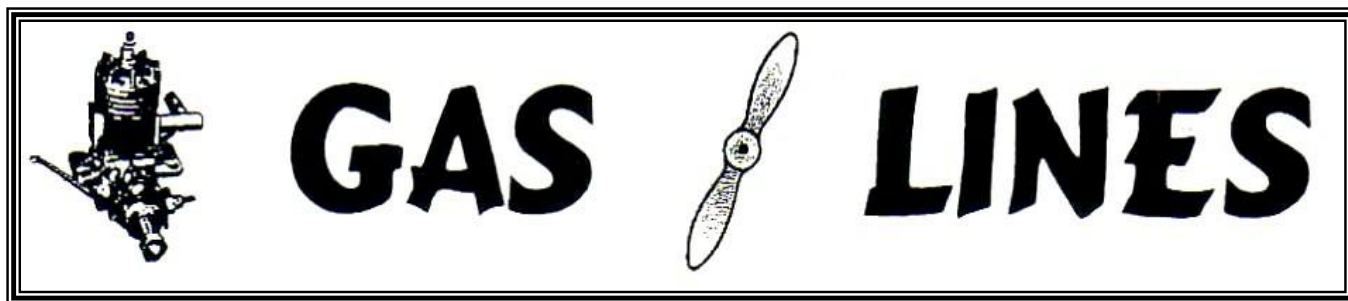

**AMA 158 – Southern California Antique Model Plane Society – Sam 13**

**SCAMPS Club Officials**

<b>President</b>	Bernie Crowe	(858) 204-7987	bcrowe42@gmail.com
<b>Vice President</b>	Hal Cover	(909) 591-3717	hcover3646@hotmail.com
<b>Treasurer</b>	Lance Powers	(714) 307-3040	lancepr@mac.com
<b>Newsletter Editor</b>	Clint Brooks	(562) 349-2672	scampsedit@yahoo.com
<b>Meeting Coordinator</b>	Mark Williams	(909) 996-2942	marknjeannie@gmail.com
<b>Safety Officer</b>	Paul Guiso	(714) 963-7270	PCGuiso@socal.rr.com

**President's Corner**

*by Bernie Crowe*

I recently had the good fortune to have my aging but superbly flying *Lamb Climber* returned to me for a second time in two months, this time by Joe Jones' grandsons! Thank you to them; it's a pity that Joe had to lose his *Gollywock* to make this possible... My plane was out on the northern edge of the field for about three weeks, and the sun and wind had taken its toll! Most all the tissue was a tattered remnant of its former self, but the areas covered in Polyspan (fuselage and wing inboard panels) were virtually unscathed! Now, Polyspan is heavier than tissue, I know, but if my whole plane had been Polyspanned I'd probably be back out flying the old Climber this week instead of staring at the bones on my workbench waiting to be re-covered. Just a thought.

\*\*\*

We had a visitor at Taibi Field on Wednesday 16<sup>th</sup>. Jesus Blanco was clearly excited by all the free flight activities and asked if Hal Cover was on the field. He said Hal had helped him and given him a plane some years ago and he wanted to say thank you. Jesus was born in Cuba but moved to the US in the sixties and now lives locally. He said he was able to attend the King Orange contest in Florida in 1954 as a high school student and that hooked him on aeromodelling. He wants get more involved and promised to be at the field again next week.

\*\*\*

We owe a debt of gratitude to those stalwart folks who open up their homes to hold Club meetings. It takes a lot of work to set everything up and put up with a crowd of unruly modelers for several hours, not to mention the amount of work involved in cleaning up our building areas so as not to be embarrassed in front of our fellow Club members. But in addition to all this most hosts provide comestibles and libations for all attending, at not-insignificant cost to themselves. I have asked recent hosts to let me know how much they spent on food and drink, with a view to providing monetary compensation for future meeting hosts. Stay tuned.

\*\*\*

And speaking of coming meetings, Hal Cover has finalized the meeting calendar for the rest of the year (seen elsewhere in this fine publication), and now we are in the process of filling out the calendar with a series of topics to be presented at these meetings. And I have been admonished not to let these presentations be as long and utterly boring as was the last one (given by yours truly.) Possible topics: engine tuning and running-in; prop carving; trimming for performance, and more. Stand by...

## **SCAMPS Club Meeting Schedule for 2018**

We have essentially filled the meeting schedule for 2018. Meetings will be at noon on the dates noted below.

We also have organized a real Christmas party. It will be at Jane and Hal Cover's house on Saturday December 8<sup>th</sup>. It will be catered and there will be a charge based on the cost of the catering.

### **CLUB MEETINGS:**

**July 7<sup>th</sup>** at Jack Guiso's home.

**August 4<sup>th</sup>** at Joe Jones home

**Sept 8<sup>th</sup>** (tentative) at Eric Strengell's home

**October 6<sup>th</sup>** at Lance Powers home

**December 8<sup>th</sup>** Christmas party at Hal Cover's home.

We will keep you updated as to location and schedule changes.

-Hal Cover

**SCAMPS NEWS**

*by Clint Brooks*

Here are some nice pictures from the April SCAMPS/San Valeers Spring Annual, provided by Brian Furatani-one of the best and most active photographer out there for free flight in SoCal. Between him and Arline Bartick we are regaled with beautiful images of us doing what we love best. Enjoy-the crowd at the field was impressive and the flying conditions great.



Bernie Crowe with *Creep* eNos model



*Creep* on the way to a max flight



Bob Scully with a beautiful *Satellite*





Jeff Carman



Ron Thomas



Clint Brooks

The San Diego Orbiteers and Fresno Gas Model Club just completed their Dual Club meet in Lost Hills. It's the 60<sup>th</sup> Anniversary of the Orbiteers and I believe the 70<sup>th</sup> anniversary for the Fresno Gas Model Club, which according to Doss Porter makes it the second longest lived model airplane club in the USA. I'm not sure what club is older-my guess is the Brooklyn Skyscrapers?

SCAMPS were there in the form of Jeff Carman, Carl Redlin, Mike Mayea, Daniel and Allen Heinrich, Bill Booth and myself. There was a group of FAI F-1B flyers assembled thanks to Bill Booth offering to CD. The rest of us flew AMA, SAM and NFFS events.

Weather was challenging in the mornings and late afternoons with strong northwesterly wind delaying the start of flying both Saturday and Sunday. By 9:30 each day the wind died off and flying proceeded, with periods of strong turbulence precipitated by frequent dust devil formations that made launching a challenge at times.

The past three contests have been setting up northwest of the normal camping area on the Holloway property, about 1/3 mile further out which kept all the models flown out of the orchards all weekend. I hope this location can be secured for future events with some grading on the now prominent dirt road leading to and from the site to level the ruts from the Fab February contest.

The Twin Pusher event was a battle between Daniel Heinrich and Carl Redlin. Both had excellent flights, with Dan's model proceeding straight line out from launch to the west before starting a turn to the right, and Carl's model orbiting up into a nice piece of air until the model was nearly specked out.

In the end, Carl bested Daniel's model by about a minute, both ending up in the same east side area after the long cross-country flight Dan's model put on.

There was also a mass Gollywock launch that I missed during a chase and I can't recall who won that one but I believe it was an Oakland Cloud Duster member who took it.

Most of the action was with AMA, Nostalgia Gas and Old Time Gas. Ron Thomas, Jeff Carman and Allen Heinrich all did well in their respective events. Jeff put on an exciting show when one of his hot C class models develop a severe wing flutter in the launch and slow rolled at full power into the ground beyond the parking area. When he returned with the model later I was surprised at how much of it was intact. The wing had suffered the most, but the rest of the model appeared undamaged. The soft ground in this area saved several models from complete destruction during the weekend although cleaning the engines is going to be a pain.

Saturday evening was a nice potluck put together by Daniel Heinrich, along with Mike Pykelney, Linda Piazza and Arline and Don Bartick. SDO had a sheet cake to celebrate the 60 years of club operations which we all enjoyed. Daniel was the grill master with hamburgers and tube steaks-the rest of us provided side dishes of mainly salads so overall it was a good feed and pleasant time spent together.

The contest ended Sunday with a classic battle in Old Time Gas between Allen Heinrich and Bud Romak. Both were putting up max after max. All the other flying had ended and everyone was watching this unfold, including the Lost Hills F.D. which had come out to see what was going on. They had no idea where the field was or what we did, so it was good they now know. I don't know

who won the contest between these two, but just having those two models in the air alone was a real pleasure to observe.

The 30th SCAMPS Twin Pusher and Lotto contest was held Sunday May 6<sup>th</sup>. Turnout was light, and the weather was a little breezy early on, giving way to nice flying conditions by 9 am or so. Most of the regulars showed up, and a surprise visit from Ken and Nancy Kaiser and also Don, who was wheelchair bound from an accident on his Quad a few weeks earlier. Apparently, his foot was caught under the wheel in motion, and a broken ankle or leg was the result-sorry Don I don't remember which. In any case, it was good to see the Kaiser team back on the field after a long layoff.

The contest gave me the chance to air out my *Miss World's Fair* and it put on three consistent flights much to my delight. I flew P-30 and also under "Nostalgia Power" with my *Ramrod 250* eNos model. It was the first time I tried the VTO launch method (ever) and found it quite fun and easy to do. The eNos approach allows you to take your time in getting into position for launch and is quite relaxed compared to the gas-powered aircraft. You also don't have the engine wailing in your face, but that's part of the charm I suppose. I understand there was some dismay about combining electric with gas models, but nobody criticized me for flying-I had a good time just getting the launch technique to work.

As the day heated up the thermal activity became more prominent, and by the end of the contest strong dust devils were starting to break out all over the field. At one point a very large one started near the parking line and moved slowly to the south to envelop the CD tent and everyone sitting in the shade. As it hit, the contest entry money was unsecured and, in an instant, I witnessed the first Cashnado ever seen in Perris. Bank notes were thick in the base, and the core had them getting sucked up to ever higher altitude. There was a mad rush to collect the ones that could be reached as they scattered over the ground. Quite a few remained airborne and at one point I could see five or six starting to speck out in the sky, heading east. People spread out into the surrounding field to look for stragglers, but nothing was recovered from this group. As Hal put it, at least we had paid dues to the Thermal God Hung with this mishap. I thought he/she preferred models and remorse over cash, but maybe next year we'll be rewarded in some manner (I'd like my *Red Buzzard* back please).

Regardless, it was a great contest and many thanks to Hal and Jane Cover for hosting and handling the awards at the end. Thanks also to all who came out and joined in with the fun.

### **2018 Lotto Contest Results**

<i>Event/Contestants</i>	<i>Time</i>	<i>Place</i>
<b>Twin Pusher</b>		
Joe Jones	171 secs	1
<b>Small OT Rubber</b>		
George Walter	441 secs	1
Joe Jones	434 secs	2
Bernie Crowe	37 secs	3

<i>Event/Contestants</i>	<i>Time</i>	<i>Place</i>
<b>Large OT Rubber</b>		
Clint Brooks	494 secs	1
Joe Jones	435 secs	2
George Walter	429 secs	3
<b>Perris Special</b>		
Hulan Mathies	984 secs	1
Ray Peel	900 secs	2
<b>P-30</b>		
Clint Brooks	360 secs	1
Lance Powers	355 secs	2
<b>Nostalgia Power</b>		
Jeff Carman	540 secs	1
Ken Kaiser	514 secs	2
Hulan Mathies	507 secs	3
<b>Modern Power</b>		
Jeff Carman	506 secs	1
Ken Kaiser	503 secs	2
Phil Ronney	434 secs	3

## SCAMPS Club contest May 9 2018

*by Bernie Crowe*

We got great weather and a pretty good turnout for May's contest, but very little actual participation. Only five of us flew in four separate events - AMA Gas A-B-C-D, Mulvihill (unlimited rubber), 4oz/8oz Wakefield, and Electric Nostalgia. We'll get to the why later.

SAM early Wakefield models, 4oz (1934 to '37) and 8oz (1937 to '51) have proved popular with our Club in the past, but on this occasion only Fernando Ramos flew. Hal Cover's much flown "Bert Judge Wakefield" winner was absent, along with its owner. Needless to say, Fernando won!

Mulvihill models are essentially unlimited rubber under 300 sq. ins. George Walter lost his great "Dawn Patrol" last year and is at this time building a replica of past member Al Richardson's "Long Shot", along with a couple of other Club members. So instead he flew his "Red Buzzard" to victory over my "Terraphobia". On this occasion my plane would have been more aptly named "Avi-phobia" because it was most unwilling to stay long in the air due to a damaged front end.

In Nostalgia Electric Clint Brooks flew his "Ramrod 250" to an easy win over my struggling "Creep", which almost crashed on its first flight before squeaking out a 140, but then cemented its incompetence by flying into the ground on the next. Only my RDT saved it from oblivion. And a week later it completed the self-destruction by doing the same thing again and folding the wing when I RDTd it. Clint's plane flies great!

In AMA Gas, the only flier was Jeff Carman, who put up four clean maxes to show he didn't need competition to spur him on. There were several other gas fliers on the field, but the lament was that they were all getting ready for the Dual Clubs meet at Lost Hills in two weeks. I always felt that the best preparation for a contest



was contest flying, which was one of the reasons we initiated these low-pressure Club contests eight years ago. Just sayin'

Our next contest will be held June 13th. We'll be flying OT Small Rubber (combined stick and cabin), all high-thrust Gas (AMA and Nostalgia combined), F1S (E36) Electric, and for fun, tiny E-20s. Shouldn't be too hot, so come on out and join us.

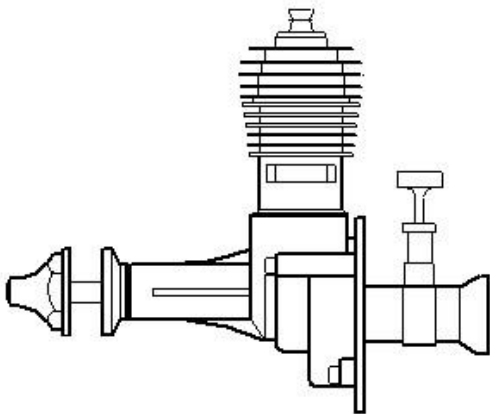

## 2018 Free Flight Contest Schedules -Perris/Taibi Site Unless Otherwise Noted

SCAMPS Monthly Club & Sanctioned Contest Schedule 2018 V2.0					
Mo	Day	Rubber	Power	Electric	CD
Jan	17	P30 / Jimmy Allen	1/2A, ABC, D/supD AMA Gas	F1S (E-36)	B. Crowe
Jan	20	<b>Haggart/Bowden-Perris</b>			<b>M. Myers</b>
Feb	7	OT Small Rubber (comb)	1/2A, ABC Nos Gas	E Nostalgia	H. Mathies
Mar	11	<b>SCAMPS 13th Annual Taibi Contest-Perris</b>			<b>J. Jones</b>
Mar	14	P-30 / Greve-Thompson combined mass launch	All 1/2A AMA + Nos Gas	AMA Electric	J. Jones
Apr	11	OT Large Rubber (comb)	Perris Special, OT Sport Glow	F1Q + F1S	R. Peel
Apr	22-23	<b>SCAMPS/SCIF Texaco-Lost Hills</b>			D. Heinrich
May	9	4oz Wake / 8oz Wake + Mulvihill	1/2A, ABC, D/supD AMA Gas	E Nostalgia	J. Carman
May	6	<b>Lotto/Twin Pusher-Perris</b>			H. Cover
Jun	13	OT Small Rubber (comb)	All Hi-thrust AMA + Nos	F1S + E-20	H. Cover
Jul	11	P-30/Comml Rubber	Perris Special, OT Sport Glow	AMA Electric	L. Powers
Aug	15	OT Large Rubber (comb)	1/2A, ABC, D/supD AMA Gas	E Nostalgia	P. Guiso
Sep	12	OT Small Rubber (comb)	All 1/2A AMA + Nos Gas	F1S + E-20	R. Thomas
Oct	10	Nos Wake / Nos Rubber	Perris Special, OT Sport Glow	AMA Electric	P. Ronney
Oct	20-21	<b>SCAMPS/SCIF+San Valeers Nos-Lost Hills</b>			D. Heinrich
Nov	14	P-30 / Jimmy Allen	1/2A-A, BCD AMA Gas	F1S	G. Drake
Dec	12	Gollywock Mass Launch + OT Small Rubber (comb)	1/2A, ABC Nos Gas	E Nostalgia	B. Crowe

San Diego Orbiters Monthly Club & Sanctioned Contest Schedule 2018					
Mo	Day	Rubber	Power	HLG/CLG	CD
Jan	29	P-30 (no rain date)	Any-Gas or Electric	Any	Mike Pykelny
Feb	18	OT/Nostalgia rubber (no rain date)	Any-Gas or Electric	Any	Mike Pykelny
Mar	18	Coupe (3/25 rain date)	Any-Gas or Electric	Any	Mike Pykelny
Apr	15	P-30 Memorial (4/29 rain date)	Any-Gas or Electric	Any	Mike Pykelny
May	19-20	<b>SDO/FGMC FF Bonanza-Lost Hills</b>			
May	27	<b>Coupe make-up for 3/18 contest</b>	Any-Gas or Electric	Any	Mike Pykelny
June	24	OT/Nostalgia rubber (no rain date)	Any-Gas or Electric	Any	Mike Pykelny
July	N/A	No Contest Planned			
Aug	N/A	No Contest Planned			
Sep	16	Coupe (9/23 rain date)	Any-Gas or Electric	Any	Mike Pykelny
Oct	14	P-30 (10/28 rain date)	Any-Gas or Electric	Any	Mike Pykelny
Nov	11	OT/Nostalgia (11/25 rain date)	Any-Gas or Electric	Any	Mike Pykelny
Dec	9	Coupe (12/16 rain date)	Any-Gas or Electric	Any	Mike Pykelny

OASIS Squadron FAC-20 Outdoor Schedule 2018				
Mo	Day	Events	Location	CD
Mar	28	Greve/Thomp Combined, Jim. Allen, All Sky Chief	Perris	Roger Willis
Jun	11	Blur Race, BiPl Mass L., OTRF	Perris	Roger Willis
Oct	10	WWII Combat, FAC Rub. Scale, 1/2 Wakefield	Perris	Roger Willis

San Diego Scale Staffel Outdoor Schedule 2018				
Mo	Day			CD
Feb	24-25	Flying Aces Club	Perris	George Mansfield
Jun	9-10	Flying Aces Club	Perris	George Mansfield
Nov	17-18	Flying Aces Club	Perris	TBD



Note to guests interested in observing or flying free flight models at Perris:

The usual time to catch us in the act is in the morning. Most Saturday mornings are when people come out to test fly or tune up their models and skills, and just have a good time. You can observe a handful of top FAI rubber and glider flyers along with others flying a range of model types- mostly endurance rubber powered and electric or gas powered. Scale free flight models are flown when the Scale Staffel has their FAC contests also noted above. These are typically conducted over two day periods to get in all the event categories normally flown. Flying usually starts 7-ish and ends late morning depending on winds. There is usually a group that flies on Wednesday as well if you would rather make a mid-week trip. Come join us-see the map above for an idea on directions-it's on the east side of the 215 freeway, off San Jacinto Ave.-there is a dirt road entrance on the right.

## SCAMPS Membership Form



We are accepting memberships to the SCAMPS (Southern California Antique Model Plane Society) at this time. Our membership is for one calendar year, from January through December. Membership includes a monthly newsletter, with the latest information on contests, building projects, flying news from Perris, plus much more. We also host several contests each year, plus have a weekly fun-fly at our Perris, CA field. These happen every Wednesday morning, weather permitting. There is also another group of SCAMPS that fly on the weekends. Members also receive a membership card and SCAMPS decal sheet. All members are welcome to attend monthly meetings, where it is more a social gathering, than a formal meeting. Refreshments are served at all meetings and it is fun to catch up on the latest happenings with your friends. We hope you decide to join in on the fun. If this is a renewal, simply write your name below and send your dues. I have all your other information on file.

**Dues are \$30 for regular newsletter snail mailed, and only \$15 for members who receive the newsletter via E-mail ONLY. All funds should be made payable to the SCAMPS. Please send your dues to Kevin Sherman, 1521 S. Normandy Terrace, Corona CA 92882-4036.**

Please check all that apply

Renewal  New Membership  E-mail Newsletter  Regular Mail Newsletter

Name \_\_\_\_\_ Phone Number \_\_\_\_\_

Address \_\_\_\_\_

City \_\_\_\_\_ State \_\_\_\_\_ Zip Code \_\_\_\_\_

E-mail \_\_\_\_\_

AMA Number \_\_\_\_\_

If new, how did you hear about our club? \_\_\_\_\_

\_\_\_\_\_



# 2018

## 50<sup>th</sup> SAM CHAMPIONSHIPS

September 24 – 28 Muncie, IN

Celebrating 50 years with the following perks....  
Reduced Entry & Banquet Fees plus Free lunch each day

Flying ALL FF Events in the SAM Rule Book  
*Except the 2 Texaco Events & Fuel Allotment*

Nostalgia 1/4A, Early 1/2 A, 1/2A, A,B & C  
Sm & Lg Rubber. Classic 1/2A, A/B, C/D  
&Towline. SM & LG Nostalgia Electric.  
Vintage FAI  
plus a few Flying Aces Events

At the Pilot's Meeting on Monday we will consider allowing HL Gliders to be disc launched.

### National Cup Competition

(4) FF Championship Crystal Mug Awards

*Note: OT R/C FF will be flying  
a full agenda per the SAM Rule Book.  
Current or 2019 Membership requested*

Additional Information see SAM SPEAKS or SAM Website [www.antiquemodeler.org](http://www.antiquemodeler.org)

**Contact Information:**

Contest Manager: Tom Boice 937-478-5900

FF Contest Director: Ted Firster 951-830-0414

RC Contest Director Tom Boice and Glenn Poole