

Points of Interest:

- Upcoming Events.
- From the President - Paul Farthing.
- Members' Letters.
- Western Australia reports - Paul Baartz.
- Control Line Roundup - David Owen.
- Before Glow Plugs - Roy Bourke.
- Electric Oldtimer - Lou Amadio/AVNZ.
- Tomboys and Cox's.
- Eastern States Gas Champs, Wangaratta.
- Back Page.

BULLETIN No. 154
September - October
2008

Worth Noting Inquiries have been received about the dates for the 2009 SAM Champs. Some folks are planning their fall 2009 schedules and wanted the exact dates.

The 2009 SAM Champs will be flown at El Dorado Dry Lake just outside Boulder City Nevada---the same venue where we've held the 1997, 2001, 2005 and 2007 SAM Champs. The flying dates are Monday October 5 through Friday October 9, 2009. We'll have registration at the hotel on Sunday, October 4.

Since the Boulder City Chamber of Commerce played a big part in getting us a permit to fly on the lakebed that week, we're calling it the "Boulder City Champs". But for you who think of it as the "Las Vegas Champs" so be it. But Boulder City has been nice to us, and it would be appreciated if you gave the restaurants and businesses in town a look see and a thank you.

The headquarters hotel will be the Fiesta Henderson--the same hotel that we used for the 2005 and 2007 SAM Champs. It's a bit early to start registering there, but we have a special SAM rate that's actually \$3 a night less than they charged us in 2007.

I'd also ask you SAM Talkers put the dates of the Champs out to your fellow club members and in any club newsletters. Mike Myers. Contest Manager 2009 SAM Champs. mikemyersgln@charter.net



Muswellbrook District Model Aero Sports OLD TIMER WEEKEND

Where: Mitchellhill flying field Muswellbrook

When: Saturday 15th & Sunday 16th November, 2008.

Saturday 15th:- 9.30am start - Nostalgia then Gordon Burford then Duration

Saturday Night:- Informal Dinner at Muswellbrook Workers Club

Sunday 16th:- 8.30am Tomboy (1 hour) then ½A Texaco then Texaco

BBQ, Drinks, Coffee and Tea at field - Giveaways for Competitors

For Information Contact: Simon Bishop 02 6543 5170

~~ SPONSORED BY COOL HOBBIES ~~



DURATION TIMES

Duration Times is the official Newsletter of SAM 1788

SOCIETY OF ANTIQUE MODELLERS OF AUSTRALIA 1788 Inc.

| | | | |
|-----------------|---------------|---|---------------|
| President: | Paul Farthing | "Bogwood" Lockwood Road, Canowindra. NSW. 2804. | 02 6364-0264. |
| Vice President: | Basil Healy | 4 Casuarina Close, Umina. NSW. 2257. | 02 4341-7292. |
| Secretary: | Dave Brown | 19 Tweed Rd, Lithgow. NSW. 2790. | 02 6353-1529. |
| Treasurer: | Gail Scott | 44 Ravel Street, Seven Hills. NSW. 2147. | 02 9624-1262. |
| Newsletter: | Ian Avery | 17 Kalang Road, Kiama. NSW. 2533. | 02 4232-1093. |

Email for Duration Times - iwa@internode.on.net

UPCOMING OLDTIMER EVENTS FOR 2008-2009

| | | | | | |
|----------|-------|----------------------------------|-----------------|----------------|---------------|
| November | 8-9 | SAM 600 Cohuna Oldtimer Weekend | SAM 600 | Brian Laughton | 03 5989-7443. |
| November | 15-16 | Muswellbrook Oldtimer Weekend | Muswellbrook | Simon Bishop | 02 6543-5170. |
| November | 30 | Haddon One Day Event | SAM 600 | Brian Laughton | 03 5989-7443. |
| January | 10-11 | Wyong River Oldtimer Weekend | Wyong River MAC | Basil Healy | 02 4341-7292. |
| January | 25 | Roy Robinson Trophy Oldtimer | P& DARCS | Brian Laughton | 03 5989-7443. |
| February | 7-8 | Alan Brown Memorial Oldtimer | Orange MAC | Peter Johnsen | 02 6362-9410. |
| February | 15 | Oldtimer at Caldermeade | SWAMPS | Brian Laughton | 03 5989-7443. |
| February | 22 | Geoff Shaw Texaco Memorial | Goulburn | Paul Marshall | 02 4821-5869. |
| March | 21-22 | Oldtimer at Haddon, Ballarat. | SAM 600 | Brian Laughton | 03 5989-7443. |
| April | 9-13 | SAM 1788 Championships | Canowindra | Paul Farthing | 02 6364-0264. |
| April | 14-16 | MAAA Australian Oldtimer Nats | Cootamundra | Joe McGuffin | 02 9825-4695. |
| May | 2-3 | VIC & S.A. Oldtimer State Champs | Cohuna | Brian Laughton | 03 5989-7443. |



From the President: Hello once again. The year is drawing to an end and only one more comp, Muswellbrook, left to go. I will not be there as it is my harvest time and there is only one place I can be! So you all have a great time. I also missed Lithgow due to a prior commitment (fishing) which is an annual event for me and unfortunately, for the first time, it has clashed with Lithgow. But from all reports everyone had a good time, there was a good roll up and only the usual turbulence was there again this year. This is one field that really tests the pilot. And Beaky was there! Great to see Cec Wales take out the model concurs once again, he just keeps on building those great models.

My last comp was Wangaratta and what a great weekend we all had. Victoria, Sth.Aust and NSW were represented and despite rain and wind on Friday, Saturday, although overcast at first, was a great flying day and Sunday even better. As always the local Club gave us great support and made us very welcome and already people are talking and planning for next year. Be sure to come.

MASNSW, who are hosting the 62nd MAAA R/C Nats in 2009, have announced the dates 10-19 April, 2009, the venue being the State Flying Field at Cootamundra. Oldtimer is set for 14-16 with one electric and five IC events. See MASNSW and MAAA Web Sites for more info.

I have received four ARF Lanzo Bomber kits from Mike Walsh of Direct Models for any of our members wishing to obtain one. Price is \$300 and you can pick it up from me at home or at the Orange Oldtimer comp. I am very impressed with this kit and it really is complete. Only need radio and engine. Plug-in tip panels and removable tail assembly make for easy transport. A real winner in my opinion. Don't forget that we (1788) have Polyspan and Nitro for sale still.

Rule change time in 2009. Members have raised some matters for attention by the sub-committee. Most all are just for clarification, not much change.

They are: More positive definition of a Team Entry. In Std.Duration there's props, engine control, and engine types (i.e. any production engine up to .46, 10x6 prop and not exceed 12,500rpm) and reducing the flight time to five minutes. Include $\frac{1}{2}$ A Texaco and 2cc in the hand launch rule. The five minute rule to commence flights and when should second attempt flights occur. Fuel allocation for two stroke glow engines in Texaco. Allowing all McCoy 60's, (including Testors and approved reproductions) to be fitted with spark ignition and qualify for the 40 second engine run in Duration. Our Rules Sub-Committee member, Basil Healy, is the man to send your written thoughts to and he is awaiting your input on those items already mentioned or any others you may care to raise. His address is above and email address is <basnpat@tac.com.au>. Remember you need the support of nine SAM members to get a major rule change although Basil can make representations for re-wording and clarifications of existing rules.

The FARCON comp and the Cowra Oily Hand weekend were great events and enjoyable. It was good to fly the rarely run events and I found it quite relaxing.

The Tomboys!! What a great, fun, contest. This event is really catching on. More and more support at every event. Needs a bit of skill as well. Just remember, light, light, light, and good steady engine with biggish prop. 3cc of fuel for small and large versions. Also test your CofG, you might get a surprise where the best performance is.

Well, I did really wonder at Wang, "Where were you Beaky??" and congrats to Grahame Mitchell on his great Texaco win. Until next time, happy, enjoyable and safe Flying.

Paul Farthing. President.

MEMBERS LETTERS

MIXING OF SUPPLIED FUELS IN TEXACO EVENT.

Note: Letters have been received from a number of members re this subject since Duration Times #153. All comments were based on an official set of rules, printed from the MAAA Rule Book as found on the MAAA Web Site in 2006, following the 2005 MAAA Rules Conference, and supplied by SAM 1788 for use by Contest Directors. However upon checking with the MAAA Rule Book which now appears on the MAAA Web Site it was found that rule 5.4.3.3(b) had changed and in reply to a question put to the MAAA Secretary by Peter (Condo) Smith a reply from the MAAA Secretary was received as set out below.

In view of this occurrence all discussion re mixing of fuels is now irrelevant as rules only require one fuel to be supplied by CD. Current MAAA Rule 5.4.3.3(b) is also printed below.

Accordingly the members letters referred to above will not be printed.

MAAA Reply:

From: MAAA Secretary <secretary@maa.asn.au>
 Subject: Re Old Timer rule 5.4.3.3 b
 To: peter_condo@yahoo.com.au
 Received: Wednesday, 15 October, 2008, 2:33 PM

Thanks Peter,

To answer your question re the web site, only the MAAA Secretary has the authority to make and send changes to the MAAA web master for posting.

I have researched this for you and the rule 5.4.3.3(b) as stated, was withdrawn by the then Chairman of the Old Timer Subcommittee at the 2005 Rules Conference. See copy of the minutes below. If you have an electronic copy which differs my only explanation is that it took some time for this to be altered following the rules Conference. In support of this you will see that this particular rule was referred back to the Subcommittee for resolution, then was to be put to a postal vote. My research would indicate that the postal vote never took place so after some period of time the original wording to the rule was re-applied in place of the withdrawn version.

Regards

Kevin Dodd

MAAA Secretary

Copy of MAAA Minutes:

5.4.3.3* *b. The standard 4 stroke glow fuels / fuel supplied by the event organizers shall contain: 15-20% oil, 5 -10% nitromethane and the balance methanol. The actual percentages to be used for an event shall be determined and made known before the event. Both castor and synthetic oil fuels to be available.

5.4.3.3 b. was withdrawn by the Chairman and will be referred back to the Sub-committee for resolution and then sent for a Postal Vote.

***ACTION*:** Technical Secretary to advice Sub-committee.

MAAA Rule 5.4.3.3(b) from current MAAA Old Timer Texaco Rules on MAAA Home Page:

5.4.3.3 Fuels.

(a) Contestants using diesel engines shall supply their own fuel, which must comply to clause 5.4.1.4

(b) The standard 4 stroke fuel supplied by the event organisers shall contain: 15% oil, 5% nitromethane and 80% methanol.

From Don Southwell:

(Editor: The first part of Don's letter dealt with mixing fuels so is not produced. However Don continued:) Joys of being a CD and the frustrations of a competitor with a set of rules that need clarification on several matters. Just a few examples of the "rules as written", you may have others!

- What is the fuel allocation for two stroke glow motors in Texaco?
- Can you use a wooden 10" x 6" prop in Standard Duration?
- If "the RPM is not the subject of the transmitter control", how do you stop an engine in Standard Duration?
- How about Contest Procedures in 5.4.1.5 (c) Has any CD tried to enforce this in a normal round and when are you required to have the second attempt?

5.4.3.4 Fuel allocations.

(i) Antique Engines (spark ignition & diesel)

4.0 cc/lb

(ii) Four stroke ignition

1.5 cc/lb

Over →

| | |
|---|-----------|
| (iii) Diesel engines | 2.0 cc/lb |
| (iv) Four stroke glow engines using standard fuel as supplied by the event organizers. | 3.0 cc/lb |
| (v) Four stroke glow engines not using supplied fuel | 2.0 cc/lb |

5.4.10.2 (b) The propeller to be used for this event is to be a 10"x6" fibreglass or nylon injection-moulded propeller which must be as purchased.....

5.4.10.2 (c)engine to be fitted with a mechanical linkage set at the recommended RPM the RPM not to be the subject of transmitter control.

5.4.1.5 (d) Models must be air borne within five (5) minutes of round or fly-off being declared open by the Contest Director (radio frequency clashes permitting). Failure to become airborne within five (5) minutes will result in an attempt being awarded. The second attempt does not have to follow the first attempt immediately.

From Peter Scott:

I find it unbelievable that the Nats have been broken up and I think the decision stinks! Were we asked what we wanted? NO!!

Paul Farthing and other people who I spoke to at Wangaratta, thought that the Easter SAM Championships at Canowindra might be accepted as the Nationals contest as well as the SAM Championships. Of course the Thursday Free-flight events, the control line fun events nor Tomboy event would not be Nat's events.

However MASNSW have since announced a five events, Oldtimer Nats Program, starting with Electric Oldtimer, on the Tuesday after Easter, running through to Thursday, at the Cootamundra State Flying Field, and this program has since been confirmed as final by MASNSW President, Joe McGuffin.

The other event which badly needs a boost is the Muswelbrook Oldtimer Weekend. It started out as a five contest weekend with fun events for the ladies and indoor. It has ended up a low-key, four event contest. Please organisers, put in the effort and make this event live up to its promise of a great weekend away. Suggest:- Saturday - Nostalgia, Burford, and Duration with Indoor evening, if possible. Sunday - 1 hour Tomboy contest, 1/2 A Texaco then Texaco. I am willing to be C.D. for some events - or can help in any way.

Let's make this the event it started out as - and fliers, please support it.

From George Car: I was very interested to read (DT, 153) the letter by Dave Brown correctly upholding the rules, while on the facing page seeing the results for the FARCON Nostalgia event.

All models listed as having flown were dated as either '36 or '38. The design rule covering Nostalgia (4.1.1) mentions...on or after 1 Jan 43 and on or before 31 Dec 56.

Nostalgia - FARCON Contest on 23-24 August, 2008.

| | | | | |
|----------------|-------------------|-----------|------|-----|
| Peter J. SMITH | 1954 Spacer | K & B 40 | 1260 | 671 |
| Basil HEALY | Sunstreak | ?? 40 | 1260 | 580 |
| Peter SCOTT | 1953 Spacer | OS25 | 1248 | |
| Dave BROWN | Civy Boy | Merco 61 | 1228 | |
| Jim RAE | 1954 Gold Dust | OS Max 29 | 1227 | |
| George CAR | 1953 Stomper 120% | OS 25 2/s | 1207 | |
| Paul FARTHING | 1950 Hyphen | OS 40H | L/O | |

Am I correct in assuming that all the models listed in the results were in fact ineligible? Given that I flew a Stomper (1954) for several flights in the event (though not listed), all flights sub max, does that nevertheless make me the winner of the event? Ha ha, Scotty! Lets have the trophy, then.....

(Editor: George is more observant than your editor... the '38 Antique results were duplicated under the heading of Nostalgia. Brownly supplied the correct Nostalgia result which appeared in the electronic copy of DT153 and above:

By The Tips Of Your Fingernails! - Condo 08 at WANG

Well the 1/2A fly off got away on a overcast day - they were more like bumble bees as they struggled to get up high,

Now Dave Markwell flew down wind, a risky move at best.

Condo had the best time but Dave was just a spec, Scotty was still there but not for long.

Dave made a beeline for home, the landing area was marked well, but Dave just fell a few feet short, what hell!

Condo thought he might win, as Scottie often lands out rather than in.

But Scottie found a thermal at 10 ft, he did a couple of circles trying to compete,

then the greedy bugger did a few more!

Condo thought he still might win but Scottie, with a grin, wasn't so sure.

Scottie's TIMER had him by the arm, her fingernails were digging in.

She told Scotty, in no uncertain terms, he had bloody well better land IN!!!!

Western Australian Report - From Paul Baartz.

WA State Championships 2008 OT Texaco

Once again the weather Gods smiled on an OT contest and the thirteen starters enjoyed near perfect conditions for this event. It was cool with a steady but light north easterly breeze and very little thermal assistance unless good height was achieved under power as the air was quite buoyant at heights.

Several minor disasters during the event affected some scores and Alan Trott managed to write off his Bomber on its second flight due to radio problems. Only three qualified for the fly-off with frequent flyers in Ray and Mark Sherburn and newcomer to fly-offs in Les Isitt. Junior member Aaron Dickens battled manfully to finally get his engine performing in a reasonable manner and by the contest end put in a great time for his last flight. Graeme Cooke could not coax maximum performance from his Anderson Spitfire ignition engine and just missed being competitive in terms of the competition.

The fly-off was in very neutral lift air and the three took off very close together, Mark Sherburn achieved better height than the other two and all glided down at a steady rate giving the win to Mark.

Oldtimer Texaco Results:

| | | |
|-----------------------|------------------------------|------------|
| 1. Mark Sherburn | 85%Bomber/Magnum.52fs | 1800 + 711 |
| 2. Ray Sherburn | Flamingo/ Magnum.61fs | 1800 + 641 |
| 3. Les Isitt | 85%Bomber/Magnum.52fs | 1800 + 348 |
| 4. Richard Sutherland | Buccaneer/Drone Diesel | 1781 |
| 5. Greg McLure | 85%Bomber | 1600 |
| 6. Rick Rumball | 85%Bomber/Magnum.61fs | 1393 |
| 7. Ian Dixon | Anderson Pylon/OS.60fs | 1342 |
| 8. Paul Baartz | 85%Bomber/OS.40fs | 1172 |
| 9. Scott Matthews | Quaker Flash/Enya.25 diesel | 1061 |
| 10. Graeme Cooke | Lanzo Rec Break/And Spitfire | 983 |
| 11. Gary Dickens | Trenton Terror/OS.40fs | 767 |
| 12. Aaron Dickens | 75%Bomber/Magnum.30fs | 617 |
| 13. Alan Trott | 85%Bomber/ASP.61fs | 454 |

Oldtimer 1/2A Texaco Results:

| | | |
|-----------------------|------------------|------------|
| 1. Kevin Hooper | Stardust Special | 1080 + 550 |
| 2. Richard Sutherland | RC-1 55% | 1080 + 502 |
| 3. Paul Baartz | RC-1 55% | 1080 + 330 |
| 4. Rod McDonald | Strato Streak | 1080 |
| 5. Ian Dixon | 50% Bomber | 1052 |
| 6. Troy Latto | Coronet | 772 |
| 7. Gary Dickens | Atomiser | 720 |
| 8. Rick Rumball | RC-1 55% | 192 |



WA State Champs 2008 OT 1/2A Texaco

This event was held on the 5th October at Mundijong and despite the cold southerly breeze the flying conditions were quite acceptable with several very large lift patches drifting through the area during the morning.

A small field of eight flyers competed and although numbers were down the quality was up so to speak and half of the field made the fly-off with another one that should have had it not been for out-landings caused by wind gusts right on landing approach.

Kevin Hooper at last broke the drought and recorded his first win of an Old Timer competition, in a dramatic fly-off. Three were battling hard to stay aloft and gain the first place but Richard Sutherland landed first, leaving Kevin and Rod McDonald to square off for the title. Having taken off almost simultaneously and both being at practically the same height it looked like going down to the wire as landings became inevitable when a gust of wind lifted Rod's model away from the landing area and caused him to land 'out' thereby reducing the flight to a zero score and giving the win to Kevin.

WAMAC president Gary Dickens made the presentations at the conclusion of the event.



Australian Vintage and British not-so-Vintage Control-line Flying

From David Owen.

My wife, Celia, and I recently spent several weeks in the UK and I had the opportunity to go to the British Model Aircraft Nats at Barkston, near Grantham and the Barton World Cup, just outside Manchester.

My first choice had been the SAM 1066 Champs, which were held in late August at Middle Wallop, an RAF parachute field near Andover. However, at that time I did not have a car and despite much help from Ron Moulton, was unable to arrange a lift. So the British C/L and R/C Nats it was, and what a spectacle compared size-wise to our own Nats.

I had been to Barkston before, some 20 years ago. Though it is still an active RAF base, the twitchy missile platforms I saw then around the perimeter appear to have been moved elsewhere, making for a less tense atmosphere. After all, if someone started a barney, a missile base may not be the safest location! The BMFA British Nats is a 3-day affair and there are a lot of events to fit in. For this reason, the British Nats F/F events are held at another location and time.

It was just not possible to take a photograph which would convey the tremendous number of competitors, spectators, cars and vans or the extent of the trade stand area. The latter must have covered several acres, with stalls thronged by keen shoppers buying and carting home great quantities of ARF models and accessories. The biggest swap meet I have ever seen was also conducted in a very large hangar, with most of the merchandise seeming to be unused ARF models, probably purchased at Barkston the previous year. And so the cycle goes!

I only had one day there, courtesy of a lift from well-known vintage flyer, Steve Betney. Such was the whirlwind nature of the visit that I just tried to take it all in, without any real concentration on specific events. There were many control-line circles in action on the day and I tried my hand at Carrier Deck, a popular event in the UK, thanks to the promotion and support of a special interest group. Despite a couple of attempts, I was unable to hit the carrier deck, landing in the 'drink' on both occasions.

A few weeks later Tony and Cathy Eifflaender accompanied us to the Barton World Cup, a highly competitive C/L event held on a small aerodrome, which is used by vintage aircraft, light aircraft and ultralights. The Barton MFC has a well-developed control-line site, with one hard speed and team race circle and a couple of grass circles for F2B. The regional police helicopter unit is right adjacent to the Barton club area, but courteously takes off and lands from the opposite direction.



Peter Halman during record speed run.

The World Cup was a 2-day event, with FAI competition only. Standards were very high and supported by European contestants as well as British. F2a (2.5cc speed) was one of the highlights for me and the good conditions gave the Irvine engine designer, Peter Halman, a win with a scorching 298.1 kph flight. Most of the competitors used the excellent British Irvine 15R engines. Peter's wife, Jo, CD'd the F2a event very competently, aided by state-of-the-art computing which gave an instant result from the electronic timing. All very impressive!



The weekend after our return to Sydney, Ian Avery, Steve Thomas, Les Callis (a visiting Kiwi and retired speed flyer) and I were guests of the Kuringai MFC for the Gordon Burford Day. This is the 2nd GB Day Kuringai have held and proved even more popular than the inaugural event. This time the club devised a World Record attempt, with eighteen models powered by Burford engines in the air at once. Divided into three circles with six to a circle, this was a successful attempt, with no casualties. Steve Thomas, who has just returned to c/l after a long break since he was a kid, flew my Sabre Trainer, the first time he has ever been more than one-up! Ten-up will be attempted at the 3rd GB Day, a date to be announced later.

The GB Day was another great tribute to one of our most famous Australian modeling pioneers, and though he is no longer active, Gordon was delighted with the enthusiasm still shown for his engines.



Top: The Participants in the new World Record of Burford engines in the air at once. Left: An array of models all Burford powered. Right: The PAW stand at the Barton World Cup Day.

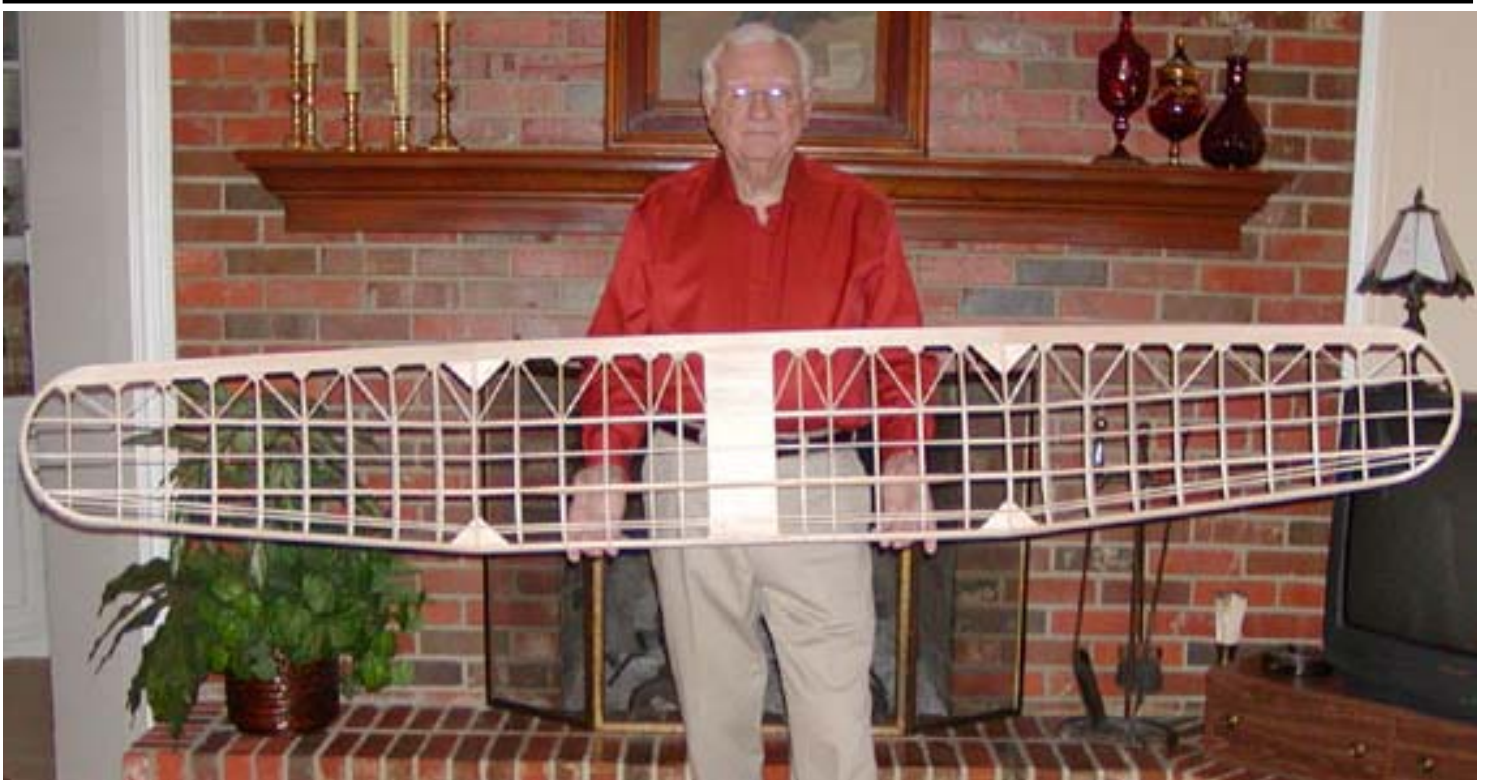

A "flutter-modified" Lanzo Bomber Wing built by SAM USA's Tandy Walker

WHAT DID WE USE BEFORE GLOW PLUGS? (A PRIMER ON SPARK IGNITION SYSTEMS)

Roy Bourke

Everybody knows what glow ignition is! Many modelers also know a bit about diesel ignition in model aircraft engines. But judging from the many questions I get when I talk about the spark ignition systems that some of us use on the older engines in Old Timer aircraft, it appears that many modelers, particularly those new to the hobby, are very unfamiliar with these "traditional" ignition systems. I thought I would offer a bit of explanation about the nature of the spark ignition systems in the older engines (pre 1950) that we use for S.A.M. (Society of Antique Modelers) competition in the "original ignition" classes.

Ironically, in 1950, everybody was very familiar with spark ignition, but few knew what glow ignition was! There was as much confusion about how this new invention (the glow plug) worked as there is now about spark ignition! Modelers were absolutely amazed that an engine would stay running after the lead to glow plug was removed. (If you remove the lead to a spark plug, not only will the engine stop but you will get a dilly of a shock as well!). And nobody could get used to these new alcohol-based fuels, having grown up with naphtha gas and the thick, dark SAE 70 oil used in spark ignition.

Before 1950, all engines were either spark ignition or diesel. But unlike modern large spark-ignition engines such as the Quadra, Zenoah or other "appliance" engines (weed-eater, chain saw, etc.) that are used to power giant scale and other large aircraft, the pre-1950 "sparkers" were not equipped with magnetos. They derived their spark from a spark coil in virtually the same way as an automobile engine. The airborne ignition system consisted of a small spark coil, a condenser (capacitor), an ignition battery (3 Volts), and a switch. The circuit was very simple:

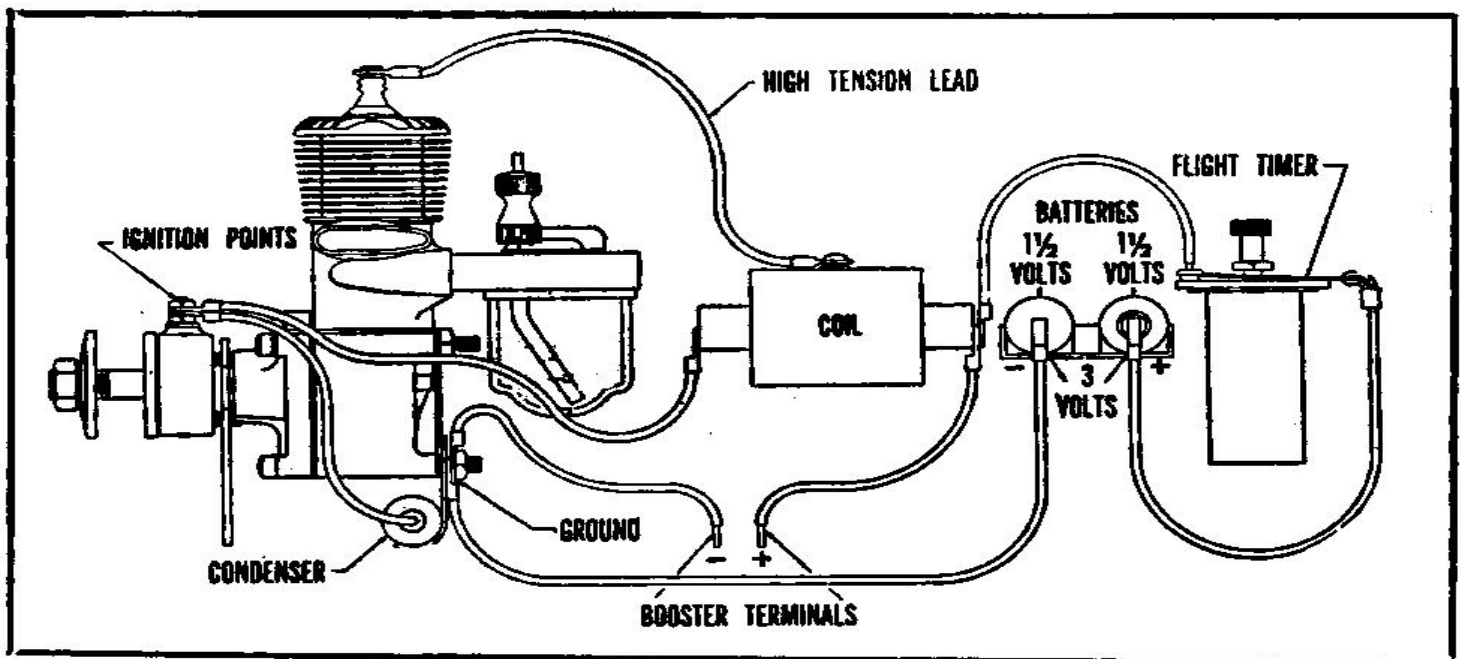

The timing of the spark is controlled by the contact points, usually on the front of the engine, operated from a cam or a flat on the crankshaft. When the points close, DC current passes through the primary of the spark coil. When the points open, the breakdown of the magnetic field in the coil causes a very high voltage to be induced in the secondary windings, which is passed to the spark plug via a high-tension lead. The spark occurs just before the piston reaches top dead center. The timing of the spark can be advanced or retarded by manual adjustment of a timer arm which rotates the bracket or housing containing the points. Normally the engine is started with the spark retarded, then the timing is advanced (the engine speeds up) and the needle valve is adjusted. In order to preserve the power in the airborne ignition battery, a booster battery is usually connected for start-up and adjustment of the engine, then disconnected immediately prior to launch.

Sounds simple enough, doesn't it? But in fact, these "simple" systems were fraught with problems and frustrations. Most of the problems came from the points, which were forever getting dirty and gooped up from oil coming out of the front bearing. Also, the points were switching all the current through the coil, about 4 Amps, so the contacts were forever getting burned or worn out, and were often out of adjustment. The spark plugs also were often fouled with oil or carbon deposits. Condensers sometimes developed leaks or short-circuits. The batteries available in those days were the carbon-zinc type, with short lives and poor performance at high currents. Occasionally we would find a broken wire or a faulty switch in the ignition circuit. All of these problems would as a minimum ad-

versely affect the running of the engine, and in most cases would completely shut down the system. Add to these the other problems inherent in engine power such as fuel flow, flooded engines, vibration, etc. etc. and it's a wonder that most of us didn't wind up in a booby hatch!

So why, you ask, would perfectly sane modelers want to voluntarily return to these frustrations and run pre-1950 engines in Old Timer aircraft? The answer lies in two marvelous inventions, the transistor and the NiCd battery. We still use the same spark coils, but now the circuit looks like this:

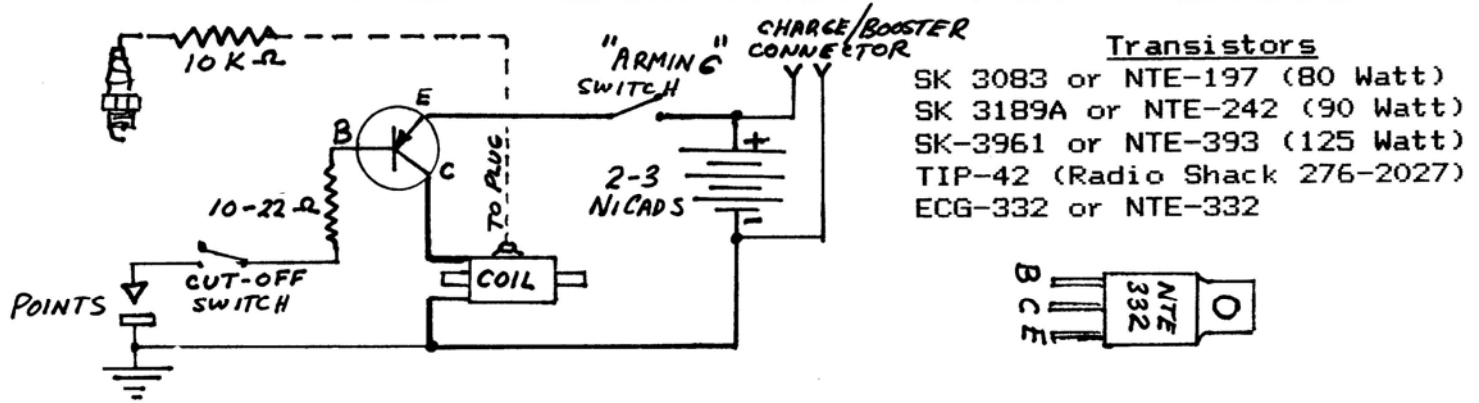

The heavy 4 Amp load of the coil is no longer switched by the points. Switching is done by a transistor controlled by the points, and the current through the points is now only about 100 mA. The points may still get quite dirty, increasing the resistance in the transistor base circuit, but the circuit will still work. Also notice there is no longer a condenser. Finally, add three small, rechargeable nicads with their high reliability and high current capability, and we have an ignition system with about 80% of the frustration eliminated!

There are still characteristics that make spark ignition a bit less reliable than glow ignition, and we have the extra weight of the coil and ignition battery to haul aloft, but these are manageable problems. And there are some advantages to spark ignition. Fuel is cheaper, it is easier to shut the engine off (with an ignition switch), and you can get good control over the RPM of the engine by varying the ignition timing (although this isn't very useful in S.A.M. competition because the engine is usually run at full speed).

Finally a word about fuels. Ignition engines traditionally were run with a fuel mixture of 3 parts white gas to 1 part SAE 70 oil. White gas is pretty hard to find these days, so most of us use Coleman camp stove fuel in its place. SAE 70 oil is also rare, but thanks to the guys that restore old Harley-Davidson motorcycles there is still a commercial supply of it. But ignition engines will also run on alcohol-based fuel, and there is a growing tendency among S.A.M. fliers in the U.S.A. to run a 3:1 mixture of methyl alcohol and castor oil (no nitromethane) in their engines. The alcohol-based fuel usually increases the RPM, allows the engine to run cooler, and makes needle valve settings less critical. However, fuel economy suffers greatly (in fact, the needle valve of some engines may be too small to handle the higher fuel flow required with alcohol). Also, old ignition engines often have plastic tanks, which must be converted to metal before using alcohol.

A few gems amongst this lot.... Murphy's Lesser-Known Laws

- Light travels faster than sound. This is why some people appear bright until you hear them speak.
- Change is inevitable, except from a vending machine.
- Those that live by the sword get shot by those who don't.
- Nothing is foolproof to a sufficiently talented fool.
- The 50-50-90 rule: Anytime you have a 50-50 chance of getting something right, there's a 90% probability you'll get it wrong.
- If you lined up all the cars in the world end to end, someone would be stupid enough to try to pass them, five or six at a time, on a hill, in the fog.
- The things that come to those who wait will be the scraggly junk left by those who got there first.
- The shinbone is a device for finding furniture in a dark room.
- A fine is a tax for doing wrong. A tax is a fine for doing well.
- When you go into court, you are putting yourself into the hands of 12 people who weren't smart enough to get out of jury duty.

Electric Old Timer

The case for brushless motors

by Lou Amadio

Right from the start we formulated the Electric OT rules to include any type of dc motor. This means brushed or brushless, with magnets made of ferrite, cobalt or neodymium. By doing this we eliminated the need for specific "motor rules" which would be almost impossible to police at competitions.

How then do you choose a motor for competition? Well, it depends on what the task is. For Duration, ultimate power is required. For Texaco, good efficiency rather than raw power is desirable.

An electric motor is a device for converting electric energy into mechanical energy. What differentiates motors is the efficiency at which they do this. Bear in mind that power wasted as heat is not available to turn the propeller.

You might recall from previous discussions (DT 148 and 149) there are three parameters that define an electric motor: 1) Kv (speed constant) RPM/volt 2) Ra (winding resistance) milliohms 3) Io (no load current) amps Of these, Ra and Io determine motor efficiency, with winding resistance the most important.

As we produce more power by drawing more amps from the battery, the current flowing through the copper windings in the motor produces more heat. Heat is generated according to Ohms Law, Power (heat) = $I^2 \times R$

In other words, heat is proportional to the square of the current. Double the current and you quadruple the heat generated across the motor windings. Excess heat can weaken magnets and, in the case of brushed motors, also damage the commutator. It is this factor which is so important in choosing the right motor for electric flight systems.

1/2A Texaco

Is an S400 brushed motor good enough for 1/2A Texaco? The following example requires a bit of maths but the conclusions are clear.

S400 6V motor weighs 70g, has a Kv of 2672 and Ra of 254 milliohms. The high Kv requires a 2.5:1 reduction gearbox to turn an 8x4 prop. Total weight is ~100g. Total cost motor plus gearbox is ~\$40. At an operating current of 10A, heat generated in the motor is $10 \times 10 \times 0.254 = 25$ watts.

ST1000 brushless outrunner weighs 50g, has a Kv of 1000 and Ra of 160 milliohms. This motor will direct drive an 8x4 prop so total weight is 50g and total cost is ~\$50. At an operating current of 10A, heat generated is $10 \times 10 \times 0.16 = 16$ watts.

Conclusion: The brushless motor weighs 50g less and delivers $(25-16)=9$ watts more to the prop. Both factors are significant in a light 1/2A model.

Use the following rules of thumb for choosing an electric motor:

- Choose the Kv (RPM/volt) to suit the battery voltage and prop RPM required (~1500Kv for 2S or ~1000Kv for 3S LiPo packs)
- Choose motor with lowest Ra.
- Lastly, allow for motor cooling. This is not normally a problem for front mounted motors in OT aircraft where there is direct cooling from the prop.

A sign of things to come?

I have just taken delivery of a new ARF kit. This is an 85% Lanzo Bomber. On first inspection the kit looks first class. More info next month when I will report in more detail.



DirectModel.com.au Presents...

The "Lanzo" Old Timer ARF

SAM Legal!
Contest Ready Model
1938 Antique Category
85% of Full Size

Wing Area: 920 sq.in
Wing Span: 80 in
Motor size: up to .40 2-stroke
Or .65 4-stroke for contest
40 4-stroke ideal for sport flying

Easy to assemble
Pre-Covered with quality film!
All hardware included!

GOING ELECTRIC WITH VINTAGE.

Thanks to the AVNZ Newsletter.

From the Editor

Last issue I gave some of my thoughts on the requirements to provide a competitive electric powered model using the recently revised rules for the RC Precision and Duration Classes.

I had based my calculations on a model of around 72 inch (1.83 metre) span and I had hoped to give you the results from testing such a model. Building progress on the model did not meet the deadline, so I opted to convert one of my existing models.

In a way this may show up any differences between IC engine power and electric drive so could prove to be useful.

The model is my old 105% Simplex of 63 inch span built from the Paul Lagan plan some years ago. A few statistics then: Wing area 677 sq ins, Minimum model weight for RC Duration 37.6 ounces or 1067 grams. Max engine size 0.30 cubic inch 2 stroke or 0.50 cubic inch 4 stroke.

The actual model in L.C. form weighed 1750 grams and had a 0.30 4 stroke for power. In this form it climbed well but never high enough for Duration. The usual times for a 25 second engine run were around 2 minutes sometimes slightly more. For RC Precision it was good and a number of these designs have had success in the hands of different pilots over the years in this class

The electric conversion was fairly straightforward as I made a ply mount plate that screwed into the end of the bearers and fitted a tray for the battery forward under the wing.

I removed the engine and its aluminium mount plate, the receiver battery, the receiver switch, throttle servo and pushrod and replaced it with the electric combination of motor and mountplate, Speed controller and a drive battery.

With this set up the weight went down to 1600 grams and surprisingly the balance point remained the same. So that was a bit of a plus.

The set up I used was a Waypoint W3020-14 motor, a Waypoint 55A Speed Controller, a Hyperion 3s (11.1 Volt) Lithium Polymer 2000 maH 23C rated battery and an APC 12x6 E propeller.



Electric Motor installed on ply mount plate and screwed to front of existing bearers

The Motor was selected from the published Waypoint data, which gave this combination the motor data as Rev /Volt (Kv) 988, and a current draw of 36 amps on a 12x6 APCE propeller (a nominal 400 watt combination). At 988Kv and around 10 to 11 volts this should mean around 10000 rpm.

On Static Test the combination tested out almost exactly as the published figures drawing 36 amps and 350 watts after around 10 seconds on a fully charged battery and 9600 revs on the 12x6.

So far so good but flight trials to come. How did they go, the answer is very well, a good climb out and an improved glide. In fact the climb was steeper and faster than the IC combination but that might be expected as the IC engine size was well down on the allowed limit, whereas, the electric combination was close to 200 watts per kilo, a high power level for this style of model. The lighter model would naturally improve the glide. Overall however with only a 20 second power run allowed for the electric model compared to the 25 second run allowed for the IC model the height gain was about the same so for RC Duration overall flight times were fairly similar and still not really competitive in this class.

I would expect that a model built closer to the minimum weight may be competitive using electric power and that will be the aim for the new model. Bonus is that the model has plenty of go and you finish up clean and green, cowpats permitting! More next issue.



The two drive layouts:

Upper is the IC combination (less Rx Battery) that was removed and lower is the replacement Electric drive. The electric drive system weighed 150 grams less than the IC combination.

From: "Anthony Tomlin" <pjt2.alt2@btinternet.com>

To: "Brian Laughton" <brianlaughton@dcsi.net.au>

Tomboy 3s

The Tomboy 3s competitions, originally devised by David Boddington and held at various flying events over the past 18 months, have turned out to be very popular. The number of entries has increased at every event and the last one, held at the Cocklebarrow Farm vintage meeting in October 2006, had 10 models in the flyoff! These high enjoyment and low cost competitions are to continue.

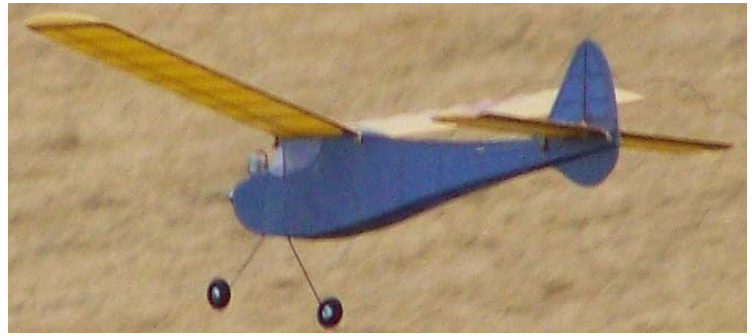

Basic Rules

A Vic Smeed 36" Span Tomboy is required powered with any type of Mills .75 with the standard 3cc tank fitted and 2 channel R/C on the elevator and rudder. A throttle or fuel cut-out can also be used. The competition consists of a number of preliminary flights [the number decided on the day] with normally a 4 minute max, and, if required a mass fly off to decide the winner.

As a Tomboy flyer I have been asked by a number of modellers for my opinion on the best covering materials, servos, batteries etc to use and if any structural mods are required. I have detailed my ideas as follows:-

Engines

I have used both the original [Mk2] Mills and the Irvine Mills. The Irvine generally is faster revving than the normal Mills with a little over 8000 rpm using a 7X5 Master or APC prop. The normal Mills seems to be happy with a 8X4 Master or even a 7X6 APC. The Mills normally revs at about 7000 rpm. The Indian Mills with careful setting up is on par. with the Irvine. The fuel I have been using with the Irvine Mills is a 50/50 mix of Model Technics D1000 and D2000. As a matter of interest it has been found that some of the Indian Mills fuel tanks have a capacity of a little over 2cc as have some of the early mills, certainly worth checking. Engine runs are normally 2mins.20secs. + with 3cc of fuel. It does pay to get the engine to full temperature before launching.

Radio and Servos

I use the Webra Nano S6 and the Hitec 04MG receivers, these weigh 19 grams and have proved very reliable. There are available now a good selection of mini/micro servos and I have used Hitec HS 55s and also Tower Pro 9 gram Micro Servos.

Battery

Recently I have been using 400mA NiMH cells manufactured by Overlander and also a company new to me called Strikalite. These batteries are carefully cycled before use. These are known as KAN cells and weigh approx 18 grams. It is possible to use smaller capacity lighter cells but normally with the Tomboy I find I can have a full days flying without charging the batteries. [Nothing worse than being in a fly off not knowing if the batteries will last]

Airframe

As the wing has to be built as per the plan with only a bottom spar I laminate a length of 1/8" sq. spruce to the bottom edge of the 1/8"X 3/8" hard balsa wing spar using cyano. The ribs are then slotted deeper to take the spar. I extend the dihedral brace by 1/2" each side and also fit small gussets at the wing tips to the L/E and T/E.

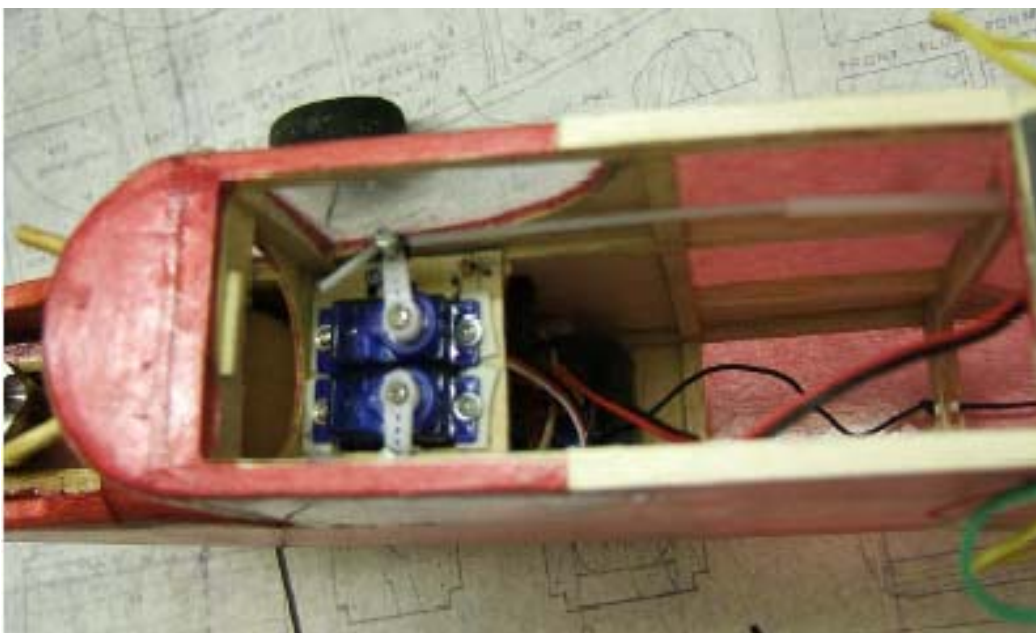

Other methods I have seen are a carbon fibre tow's cyano'd to the spar and also the spar being replaced by spruce. I modify the tailplane and fin for R/C using approx 50% of the fin for the rudder and reducing the tailplane chord to enable a 1/4"x 1/8" T/E with a 3/4" x1/8" elevator. Variations I have seen are an all moving tail and on one Tomboy the rudder was on the sub-fin. The main criteria does seem to be that the elevator needs to be powerful enough to get out of strong lift. Incidentally I at-

tach my fin/rudder to the tailplane which is retained by rubber bands. Some fliers fit the whole assembly permanently to the fuselage which can be a problem if an incidence change is required. The fuselage needs very little alteration. I have replaced the former F3 [under wing L/E] with a 1/16" ply former with two large cut outs to allow the battery to be moved forward directly behind the front bulkhead F1. I have replaced F4 [under T/E] with a 1/16" ply former the center being cut right out to leave approx 5/16" around the edges. I also fitted two 1/8" sheet gussets between F4 and the bottom longerons. Some modellers [including myself] carry the side sheeting back an



extra bay to give a little more protection to the RX and Servos. A modification I have found necessary was to reduce the wing incidence by packing up the T/E, in my case by 3/32". This improved penetration in windy conditions. I intend to increase the height of F4 on my next Tomboy with a very slight change in the top longeron curve.

Covering

The covering method I am presently using is Esaki Lite Flite Tissue over 5 microns Mylar. This needs very little dope and gives a very strong structure. Other coverings I have seen used are Starspan, Polyspan, and Litespan. These can be obtained from Free Flight Supplies and Flight-hook.

Installation

Most models have the RX and servos as far forward as possible. I mount my RX on soft foam tight up against F3 and the battery. The servos

are mounted directly above on a removable ply plate. I am using lightweight snakes from the servos to the control horns attached to the fuselage spacers with thread and a drop of cyano. Other popular systems used are push rods and closed loop [closed loop is possibly the lightest].

Thrust line, C/G and Weight

I use the thrust settings as shown on the plan and my C/G is 2 1/4" back from the L/E, both seem to be OK. Tomboys normally weigh between 11 and 16 ounces, mine both weigh around 13 ounces.

I am happy to help if you have any queries and can be contacted on 02086413505 Email: <pjt2.alt2@btinternet.com> Tony Tomlin.

COX's and COX's

From Bob Angel. samrcflier@verizon.net

I've run batches of reed valve engines for and in the 1/2A Texaco event. Those mentioned perform just as well as any of the others. I have some Texaco engines, but usually just use a plain old Babe Bee, Black Widow, etc, for the event.

However, I do fly the event in the "alternate" manner, using a 6X3 prop, letting the engine run strong and grabbing for altitude. I believe the piston/cylinder fit of a particular engine is the key to a good engine, not the exact type. I try for an engine that turns 14,000 on the ground with 15% nitro and the 6X3. One of my better engines, before I wore it out happened to be a plain old single bypass model Babe Bee.

For a dual bypass model, instinct tells us to look for one with the exhausts aligned side to side. But instinct can be wrong. The stronger engines are usually the ones aligned exhaust front and rear. Look inside and you'll see why.

When the exhaust ports are aligned side to side, the forward bypass is mostly masked off by the crankshaft.

A year or more ago Cox was selling-off "product" engines - the ones to which you refer for about \$7 apiece. A few of our local guys bought a couple apiece, and found them to be as good as any other of the reed valve engines.

I don't know anything about that red anodized crankcase model. Maybe Cox had some left over Texaco cases and used them up?



Eastern States Gas Champs - Wangaratta - 4/5 October, 2008

Top Gun: Peter (Condo) Smith.

Gordon Burford Event

| | | | | | |
|----------|----------|-------------------|--------------|-----|-----|
| Jim | RAE | Amazoom | Taipan plain | 900 | 514 |
| Grahame | MITCHELL | 1956 Dream Weaver | Taipan plain | 900 | 502 |
| Peter | SCOTT | 1953 Jaided Maid | Taipan BB | 900 | 482 |
| Steven | GULLOCK | Swiss Miss | Taipan plain | 900 | 467 |
| Dave | MARKWELL | Stardust Spl | Taipan BB | 900 | 451 |
| Brian | LAUGHTON | Dixielander | Taipan plain | 900 | 443 |
| Paul | FARTHING | 110% Pencil Jr | Taipan plain | 900 | 441 |
| Lyn | CLIFFORD | Stardust Special | Taipan BB | 900 | 418 |
| Chris | LAWSON | Foote Racer | Taipan plain | 900 | 416 |
| Peter J. | SMITH | FAIson | Taipan BB | 900 | 307 |
| Robert | TAYLOR | FAIson | Taipan BB | 893 | |

'38 Antique

| | | | | | |
|----------|----------|------------------|--------------------|------|------|
| Peter J. | SMITH | 1938 Cumulus | OK Super 60 | 1800 | 1003 |
| Peter | SCOTT | 1936 RC1 | Whirlwind 60 | 1800 | 722 |
| Jim | RAE | 1938 Pixy | ED Hunter 3.46 | 1800 | 649 |
| Dave | MARKWELL | 1936 RC1 | OK Super 60 | 1800 | 610 |
| Brian | LAUGHTON | 1936 RC1 | OK Suoer 60 | 1800 | 545 |
| Steven | GULLOCK | Polly | Burford 5cc diesel | 1800 | |
| Kevin | FRYER | 1936 Red Zephyr | OK Super 60 | 1750 | |
| Robert | TAYLOR | Cumulus | Ok Super 60 | 1678 | |
| Barry | BARTON | California Chief | DC 350 deisel | 1479 | |
| Paul | FARTHING | 1938 Flamingo | Contester 60 | 1347 | |
| Chris | LAWSON | Miss Arpiem | Amco 3.5 d | 723 | |

Duration

| | | | | | |
|----------|----------|--------------------|----------------|-----|------|
| Brian | LAUGHTON | 1941 Playboy | Irvine 36 | 840 | 1425 |
| Brenden | TAYLOR | 1941 110% Playboy | Dubjet 46 | 840 | 1226 |
| Lyn | CLIFFORD | 1938 Cumulus | YS 63 | 840 | 1108 |
| Team | SMITH | 1941 Playboy | McCoy 60 | 840 | 1103 |
| Peter J. | SMITH | 1941 Playboy | Nelson 40 | 840 | 1090 |
| Chris | LAWSON | 1941 Playboy | McCoy 60 | 840 | 1054 |
| Robert | TAYLOR | 92% Cumulus | YS 63 4/ | 840 | 874 |
| Steven | GULLOCK | 1936 75% Dallaire | OS 52 4/ | 840 | 845 |
| Dave | MARKWELL | 85% Bomber | Dub Jett 40 | 840 | 768 |
| Paul | FARTHING | 1941 Playboy | YS 53 4/ | 840 | 752 |
| Jim | RAE | 1941 Lil Diamond | Saito 56 4/ | 840 | 713 |
| Barry | BARTON | 1936 RC1 | OS 46 FX | 840 | 575 |
| Grahame | MITCHELL | 1941 Playboy | Super Tiger 34 | 840 | 468 |
| Ian | AVERY | 1941 E S Gas Champ | O.S.32 2/ | 789 | |
| Peter | SCOTT | 1942 Stardust Spl | And. Spitfire | 777 | |
| Brian | DOWIE | 1941 Playboy | OS 46 2/ | 736 | |
| Kevin | FRYER | 1936 Cumulus 92% | McCoy 60 spk | N/L | |

1/2a Texaco

| | | | | |
|----------|----------|-----------------------|------|------|
| Peter | SCOTT | 1941 Lil Diamond | 1080 | 1074 |
| Peter J. | SMITH | 1941 Lil Diamond | 1080 | 683 |
| Robert | SMITH | 1941 Lil Diamond | 1080 | 542 |
| Ian | AVERY | 1940 Playboy Cabin | 1080 | 407 |
| Brian | LAUGHTON | Albatross | 1080 | 397 |
| Chris | LAWSON | Lanzo Racer | 1080 | 387 |
| Barry | BARTON | 1942 Stardust Special | 1080 | 370 |
| Kevin | FRYER | 1942 Stardust Special | 1080 | 328 |
| Lyn | CLIFFORD | 1942 Stardust Special | 1080 | 259 |
| Paul | FARTHING | 1941 Lil Diamond | 1080 | 244 |
| Grahame | MITCHELL | Stardust Spl | 1080 | 243 |
| Dave | MARKWELL | Stardust Spl | 1080 | |
| Jim | RAE | Skyrocket | 1080 | |
| Robert | TAYLOR | 1942 Stardust Special | 1080 | |
| Geoffrey | MALONE | Lanzo Racer | 1032 | |
| Robin | YATES | Stardust Special | 1021 | |
| Steven | GULLOCK | Polly | 912 | |
| Brian | DOWIE | 1938 Bomber | 360 | |

Wangaratta Weekend - Report from Peter Scott

Pouring rain and high winds on Friday and through the night did not bode well for Saturday's events. But guess what? A perfect flying day with high cloud and very little wind.

The turn up from Victoria and South Australia was heartwarming and old acquaintances renewed. The first event run was Burford, a good roll-up, no crashes and most people got into the fly-off. I even managed a third place.

Next event was the one I asked to be included as it had been dropped two years before for no apparent reason - '38 Antique - the true old timer event, and what a terrific entry we had. Who said that the event was not well subscribed? The flying was terrific and, again, most people made the fly-off. Condo beat me into second place, the swine!

After, came the final event for Saturday - Duration. The speed and climb of this event always makes me wonder at the strength of the wings on some models. I used an Anderson Spitfire in the RC1 - not a winning combination but made up the numbers. I don't think I got into the fly-off.

The evening meal, at Treads Riverside restaurant was excellent. Most people who attended agreed that the food and company was first class.

Sunday dawned to a bright blue sky and no wind. Our first event, 1/2A Texaco, had a huge entry with most making the fly-off. It was a very close contest in which I came out on top by finding lift on the final approach to the landing area. The model gained height, much to Condo's chagrin, and flew for a further six minutes.

The last event of the weekend was Texaco which began immediately after lunch. Again, a good roll up and I used my 5cc diesel in the RC1. I did well but probably came 6th or so. Long flights, good contest.

I acted as C.D. for some contests and pushed fliers along with specific cut off times for rounds. Once people realised this was the case, things moved quickly as they put in the effort to get airborne in the time. Someone came up to me afterwards and told me how enjoyable it was to have rounds move quickly instead of hanging around waiting for a few fliers who hold up the proceedings.

Condo won 'Top Gun', results elsewhere in the magazine. I was in two minds about travelling all the way to Wangaratta to fly, as were others who were missing, but with such a good turn-up and top flying weather, those who didn't go missed out on one of the best weekends flying since Easter.

P.S. Rain and wind returned to the area Monday morning!

Texaco

| | | | | | |
|----------|----------|---------------------|---------------|------|------|
| Grahame | MITCHELL | 1936 Dallaire | Enya 60 4/ | 1800 | 1688 |
| Chris | LAWSON | 1937 Lanzo Racer | Saito 50 4/ | 1800 | 1402 |
| Paul | FARTHING | 1938 Lanzo Bomber | OS 60 4/ | 1800 | 1360 |
| Dave | MARKWELL | 1938 Bomber | OS 60 4/ | 1800 | 1338 |
| Robert | TAYLOR | 1936 Cumulus 105% | OS 61 4/ | 1800 | 1337 |
| Peter | SCOTT | RC1 | Burford 5cc d | 1800 | 1068 |
| Peter J. | SMITH | 1938 Bomber | OS 60 4/ | 1800 | 730 |
| Brian | LAUGHTON | 1938 Bomber 85% | OS 40 4/ | 1800 | 389 |
| Robert | SMITH | 1938 Lanzo Bomber | OS 60 4/ | 1800 | 140 |
| Barry | BARTON | 1938 Anderson Pylon | OS 61 diesel | 1776 | |
| Steven | GULLOCK | 1938 Bomber 85% | Enya 53 4/ | 1720 | |
| Lyn | CLIFFORD | 1936 RC1 | Enya 60 4/ | 1637 | |
| Jim | RAE | 75% Dallaire | ASP 30 4/ | 1593 | |
| Lyle | BAKER | Berryloid | Magnum 52 4/ | 1392 | |
| Robin | YATES | 1938 Bomber | OS 48 4/ | 1200 | |
| Geoffrey | MALONE | 1936 Dallaire | O.S. 60 4/ | 978 | |
| Kevin | FRYER | 1936 Red Zephyr | OK Super 60 | 643 | |



Left & above: Jim Rae and his new and Burford winning "Amazon"
Below: Chris Lawson's "Foote Racer"



Above: From Sth. Australia, Dave Markwell, assisted by his wife, sets up the Dubb Jett powered Bomber for Duration.
Left: Steve Gullock's "Polly" powered by Burford Diesel in '38 Antique



Up above left: Brian Laughton's new 1/2A Texaco "Albatross". Up above right: Chris Lawson - 2nd Place in Texaco.
Above left: Grahame Mitchell, winner of Texaco. Above right: Top Gun - Peter (Condo) Smith - he really did want to know!

~~ THE BACK PAGE ~~

Here's an "Ol' Charlie" Tip:

It's difficult to clean in between those thin metal fins, like those found on an Ohlsson engine.

I first secure the crankcase in my padded vice jaws. Next I take a piece of cord-like string (chalk-line) and apply the paint remover or engine cleaner to the string and brush some of the liquid between the fins. Then put on leather gloves, as the string will cut your hands.

Wrap the string around both hands and wrap a loop of the string between a head fin. Pull the string to and fro between the fin, removing the old crud and paint (eases the repaint process on an Ohlsson head fin assy.) and continue on doing this to all the head fins.

I then rinse and brush and use a clean piece of water soaked cord for a final clean out in the grooves. I repaint my Ohlsson cylinders using a spray can of black auto engine paint from Walmart's.

When your engine is all cleaned and reassembled I use Shaler's Rislone as an internal engine lube and as an after run oil.

In my opinion, Rislone is the best product you can use on an old time engine.

I've heard about Marvel Mystery Air Tool Oil and automatic transmission fluid being used also, however I can testify that Rislone will not, ever, dry out or harden in an engine. It will always remain a liquid, oil like lubricant. This also makes an excellent after-run lubricant.

Rislone is available at Walmart's auto parts aisle in a yellow one quart can for a couple of bucks, enough for a lifetime supply on old engines. Engine Paint from Walmart ...Works Great!

Charlie Reich <sam1781@bellsouth.net>

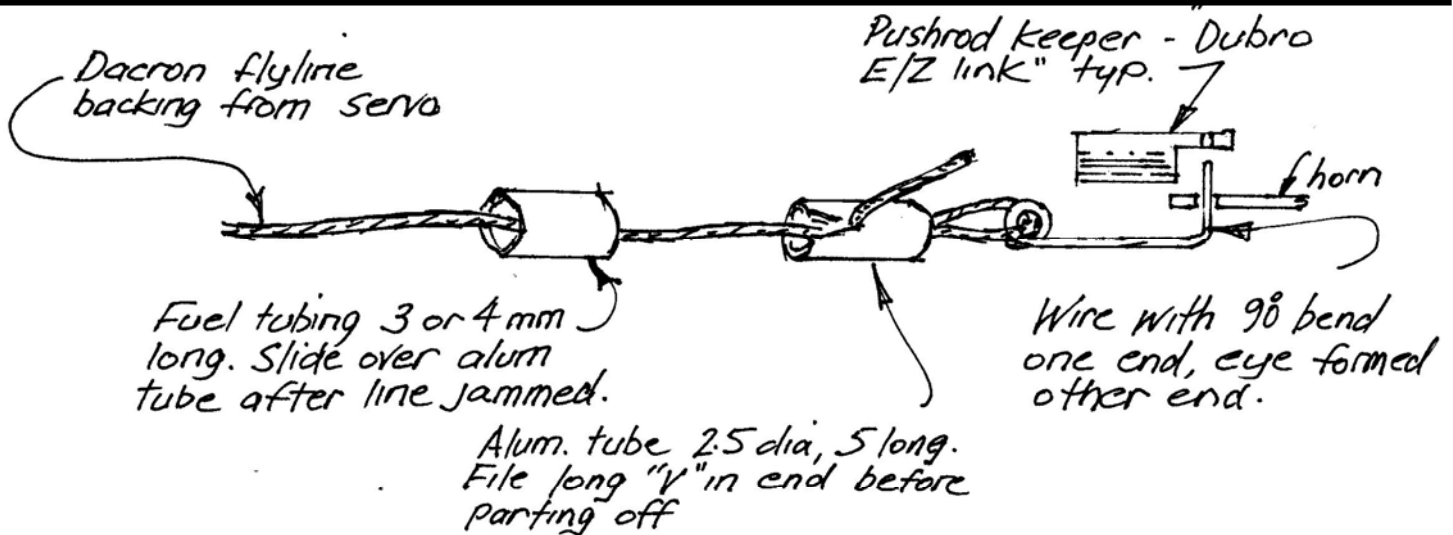
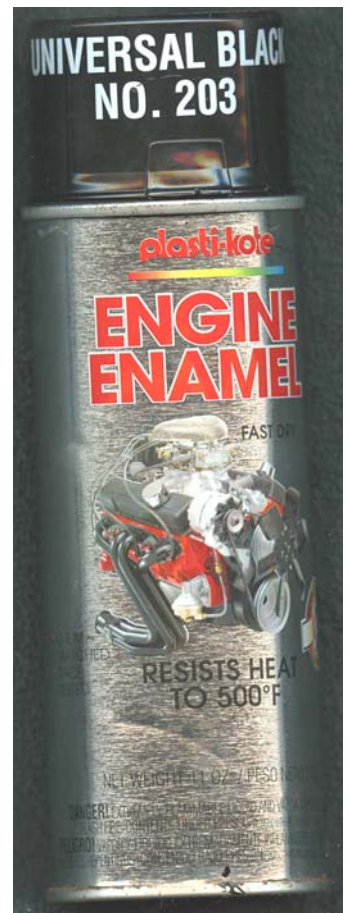

- Note:
1. Pushrod keepers available for .032", .047" & .074" wire. I find .047" most satisfactory, .032" too small for my big fingers.
 2. Pass line through fuel tubing, then alum tubing, around eye (with possibly one full turn), back through alum tube. Tighten up, slide alum up against eye and jam line in "V". Slide fuel tubing over alum tubing to secure.

ADJUSTABLE END FOR PULL-PULL LINE AT HORN

Jim Rae 23/9/08