

Points of Interest:

- From the President.
- Control Line Report from David Owen.
- Build a Super Thermic.
- Bits 'n' Pieces.
- Western Australia Report from Paul Baartz.
- $\frac{1}{2}$ A Electric Oldtimer from Lou Amadio.
- Looking Back
- O&R Tuning Tips.
- Model Knife Blade sharpeners.
- Back Page.

BULLETIN No. 147

July - August

2007

Worth Noting...

Dave Brown is doing it again.... that is, he is making up partial kit and plan sets, for a discount price, for the control line and free flight models for next year's SAM Champs and Vetrans Gathering. The models are the Aeroflyte CL Spitfire and the FF Hum Bug. The Hum Bug will make a very nice RC electric model and that is what some intend to do with it. Marvelous stuff this park-flyer RC gear that is available these days. Anyway it will be a great day on the FF/Tomboy/Hum Bug Thursday at the SAM Champs at Canowindra next Easter. Note, Easter is early next year - and the 26th SAM Australia 1788 Champs are scheduled for 20th-24th March, 2008.

Inquiries from Interstate SAM fliers have been received regarding accommodation at Canowindra for the 2008 Champs. Accordingly an Accommodation List has been forwarded with this Duration Times for all members information. If you need accommodation don't leave it too late to make your bookings. One thing in favour of next year's Champs is that it shouldn't be too cold to camp and there's always plenty of space at the caravan park.

There seems to be some renewed interest in "A Frame Twin Pusher" rubber powered free flight models. SAM 1788 used to have a mass launch "A Frame Twin Pusher" event at the Champs in the early years. Is there any current interest in trying this event again? Basil Healy can fill you in about these models as he was a regular participant in the previous events. Might be fun to research, build and fly these models once again. What do you think?

Thanks from the editor for those members who continue to support Duration Times with contributions and photos. It is always very much appreciated. Any new contributors would be most welcome.

"COOTA CUP"

WHEN: September 8 & 9, 2007

WHERE: NSW State Flying Field, Cootamundra

EVENTS: *Saturday:* Gordon Burford & Duration *Sunday:* $\frac{1}{2}$ A Texaco & Texaco
A climb & glide will be held sometime during the weekend.

MORE..... Gates open from Friday lunchtime for practice etc. Camping on field.
Canteen will be open for Breakfast & Lunch on both Saturday and Sunday.

For more info contact Sharon Smith: Telephone: 02 6942 6056 Mobile: 0422 780 645

2007 EASTERN STATES GAS CHAMPS WANGARATTA, Victoria.

29th September - 1st October, 2007.

SATURDAY 29/9 $\frac{1}{2}$ A Texaco followed by Texaco - 9-50am Briefing; 1st Round at 10am

SATURDAY EVENING ~~ Get-Together at local Eatery.

SUNDAY 30/9 10am '38 Antique ~~ 12noon Gordon Burford ~~ 2pm Oldtimer Duration.

MONDAY 1/10 ~~ Informal Climb and Glide (for those who can stay)

Catering at the field with excellent facilities. Camping on the field permitted.

For further information contact Dave Brown (02) 6353-1529 (home)

Duration Times is the official Newsletter of SAM 1788

SOCIETY OF ANTIQUE MODELLERS OF AUSTRALIA 1788 Inc.

President:	Paul Farthing	"Bogwood" Lockwood Road, Canowindra. NSW. 2804.	02 6364-0264.
Vice President:	Basil Healy	4 Casuarina Close, Umina. NSW. 2257.	02 4341-7292.
Secretary:	Dave Brown	19 Tweed Rd, Lithgow. NSW. 2790.	02 6353-1529.
Treasurer:	Gail Scott	44 Ravel Street, Seven Hills. NSW. 2147.	02 9624-1262.
Newsletter:	Ian Avery	17 Kalang Road, Kiama. NSW. 2533.	02 4232-1093.

Email for Duration Times - iwa@internode.on.net

UPCOMING OLDTIMER EVENTS FOR 2007-2008

Sep	8-9	Coota Cup Oldtimer	Cootamundra	Sharon Smith	6942-6506.
Sep	29-Oct 1	Eastern States Gas Champs	Wangaratta	Paul Farthing	6364-0264.
Oct	27-28	Glenn Simmonds Memorial O/T	Lithgow	Dave Brown	6353-1529.
Nov	17-18	Muswellbrook Oldtimer Weekend	Muswellbrook	Simon Bishop	6543-5170.
February	2-3	Oldtimer (Alan Brown Memorial)	Orange	Peter Johnsen	6362-9410

From the President

Are you getting your models organized? The flying season has started up again! There's lots coming up. Coota Cup, Eastern States Gas Champs, Glenn Simmons Memorial at Lithgow, East Coast Gas Champs at Muswellbrook in November and then the Nationals in Perth 28 December to 5 January, hosted by the Aeromodellers W.A. And don't forget Orange 2-3 February, 2008. And of course we have the 26th 1788 Australia SAM Champs at Canowindra next Easter!

All had a great time at the Rebel Club Oldtimer at Hexham and it was good to see some new models as well as some new flyers. Weather was reasonable this year although a little breezy. Had a great aerobatics display right above the flying field by a local Pitts Special (full size) and the low pass on the Pitts' departure was sensational. Thanks to the Rebel boys for organizing this very excellent entertainment.

Our thoughts and condolences are with Trevor Boundy and his family for the loss of their daughter, Kate Docherty, as a result of a motor vehicle accident in July.

A number of our members plan to attend the forthcoming Nats in Perth, including me. I will be caravanning over with Basil Healy and am looking forward to the trip. Some are flying over and others driving, so 1788 will be flying the flag in Perth at the WA Nats once again.

Those of our members who are keen Electric Oldtimer fliers, and currently run their own electric OT events, are keen to welcome and help any members who would like to try the electric side of OT flying. Don't forget they run postal comps all year round and a number of them fly these comps at the IMAC field at Berkeley each month. We have been featuring electric OT articles in past DT's and this month is no exception, $\frac{1}{2}$ A electric oldtimer being the topic. Perhaps SAM 1788 should consider bringing in electric OT in as part of SAM 1788.

Don't forget, I have supplies of Polyspan and ether for those who need it. Just contact me and let me know what you want. Ether must be delivered or collected by hand.

Looking forward to seeing you again at one of the upcoming events and don't forget the Nats!

Safe flying and many thermals! Coota Cup here we come!
Paul Farthing. SAM 1788 President.

Lithgow Oldtimer & Glenn Simmons Memorial

Saturday 27th October
2007

9-50am Briefing
1st Round 10am

'38 Antique
Gordon Burford
Duration



MAAA OLDTIMER RULES APPLY TO ALL EVENTS

Saturday Bistro Night Out, Colonial Motel

Sunday 28th October, 2007, 9-30am

$\frac{1}{2}$ A Texaco
Texaco

Featuring:

Junior Encouragement Award
Country BBQ and Canteen

Sponsored by:
Kellebts Hobbies
Echo Point Holiday Villas
Model Draughting Services

Contact Dave Brown

02 6353-1529 or daveb@ix.net.au

Control-Line Notes August 2007

From David Owen.

Early this month we attended the Oily Hand Day which is now an annual event put on by the Cowra MAC. The cold weather and windy conditions did not dampen the spirits of the 20 or so modelers who spent an enjoyable couple of days flying CL, FF and RC models at the club's new field.

This excellent field is located on Milroy Farm, just south of Canowindra. The farmer, young Matt Robson, is a modeler himself and has generously made the site available to the club and allowed the erection of excellent storage facilities, a BBQ and proper toilet.

Cowra MAC have bigger plans in hand for the 2008 Oily Hand Day and the club President, Andy Luckett, and Secretary, Ian Cole and their committee are to be commended. Have a look at their website, <cowramac.asn.au>.

Aeroflyte Spitfire

The control-line model selected at Muswellbrook for 2008 is the Aeroflyte Spitfire. This is the earlier kit version, which has a sort of elliptical wing shape and flaps, and is not to be confused with the later Spitfire kit, #114. The Spitfire is a compact little 36" stunter and is suited to most 2.5cc and up to .19 engines. Plenty of scope for colour schemes, too.

Dave Brown is again making a partial kit and plan set available to encourage interest in building and flying these older Australian designs. I bought the first kit available and it is excellent value. This time, in addition to a full-size plan, Brownny has supplied a full set of ribs with the helpful tabs attached, wing-tips, flaps, tailplane and elevators, fin and rudder, fuse sides and formers. These kits are ready now and an email to Brownny at daveb@ixnet.au will get one on its way to you at a total cost of \$30 including postage.



Bill Swan at sales@bristunt.com.au has prepared a great hardware kit for the Spitfire. This comprises the tank, bellcrank, elevator and flap horns and canopy all for \$30 postpaid and will be helpful to all those builders who are unable or unwilling to make those parts themselves. I also have a couple OS 15 Glows for sale in the event you do not have a suitable engine.

I will have my Spitfire well under construction and will include some shots in the next issue of Duration Times. In the meantime have a look at Grant Manwaring's Spitfire, which he built and flew so many years ago. He is building a new one for next year!

Lastly, though some are ready to relegate the Burford Wombat Bipe to the dustbin of modeling history, the Gunning Shire Council obviously is not. On the way home from Cowra, Ian and I detoured through Gunning to see if this once thriving Hume Highway town had survived the freeway bypass which cuts it off from the rest of the bustling world.

Not only had it survived and appears to be doing well, thanks to its proximity to Canberra, but the council have named a road in honour of the Wombat Bipe. Here is the proof!

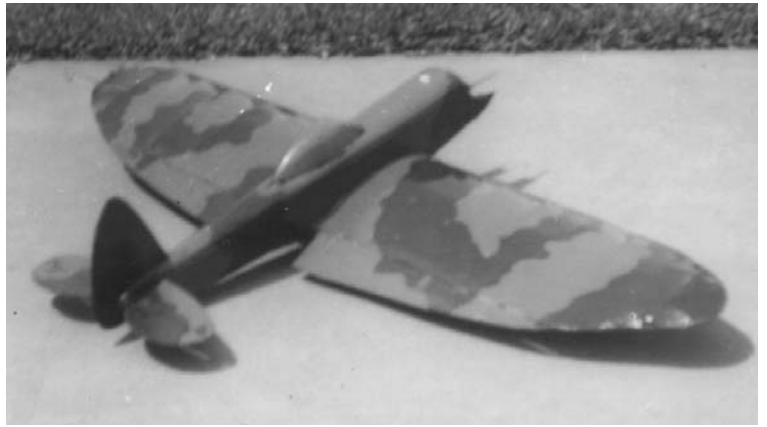

Aeroflyte Spitfire by Grant Manwaring. Very early 1960's, upright motor to make it easier to start. Photo taken in front yard at 14 Parker Street, Cootamundra. In the backyard, below is the Spitfire and the Typhoon from the Aeroflyte series of control line models.



Build the Super Thermic

From Aero Modelling Column, Aircraft Magazine, August 1953, conducted by Jim Fullarton.

Interested in building a 2.5cc Free Flighter? Then we suggest that you try this interesting high aspect ratio design by Max Nicol. It won the Class II and III event at the last National Meeting held at Bendigo.

The design of a really good model is not always the result of hours of careful planning and deliberation on the drawing board. Quite often that happy blend of proportions which makes the successful performance is arrived at by a most indirect process of evolution. Super Thermic is a good example of the latter type. The name gives a clue to the origin of the design, as the wing was originally built for a sailplane, based on Frank Zaic's Thermic design, a type with which Max had considerable success. When the fuselage of this machine was written off, he decided to try the wing on a free flight and accordingly built a large area tailplane and long moment arm fuselage as dictated by the prevailing design trends.

With an early Elfin 2.49 for power, the combination showed promise right from the start, having the classical upward spiral climb and a glide that clearly displayed its sailplane ancestry. A year's developmental flying followed, culminating in the win at the Bendigo meeting, a story which would have been much more convincing but for two of the flights being spoiled by an erratic timer.

The designer does not regard this model as suitable for beginners; although its construction is simple enough, he says that a certain amount of experimenting is needed to handle it successfully. The high aspect ratio wing has its own problems in that it is extra sensitive to any stray warps that may occur, while care must be taken with wing spars and joints to ensure the added strength that is needed.

The original model uses a radial mounted motor which bolts directly onto the front three-ply firewall, picking up nuts soldered to tinplate strips on the back of the ply. The fuel tank, also of tinplate, is fitted immediately behind this firewall, and behind it is another ply bulkhead to which is bolted the single wheel undercarriage.

If a beam mounted motor is to be used the usual pine engine bearers will be necessary, running back about four inches behind this firewall and cemented to the fuselage sides. In this case, the tank will fit between the bearers, immediately behind the motor. The basic fuselage construction consists of sheet balsa sides and formers, using a medium grade of wood only to keep the weight down. Care should be taken to minimise weight at the rear end, or heavy nose ballast may be needed. The pylon is let well down into the fuselage, the formers beneath it being slotted to half their depth.

The usual type of tail "pop-up" dethermaliser is used, with upward travel kept to about 45 degrees by a piece of cord.

Too little angle here will cause the model to descend in a true spin when the dethermaliser operates, a spectacular but rather damaging way of getting the machine down. When the correct rudder setting has been found, the tailplane should be keyed so that it cannot turn accidentally. This is done by cementing small strips of 1/16 inch ply under the tailplane on either side of the mounting platform.

The original used an air operated timer connected to a commercial cut-off valve as shown, but in the light of experience Max would prefer a clockwork timer for greater accuracy. The entire model is covered with lightweight Modelspan tissue, doped and fuel-proofed, and should be ballasted to balance at about one inch forward of the trailing edge.

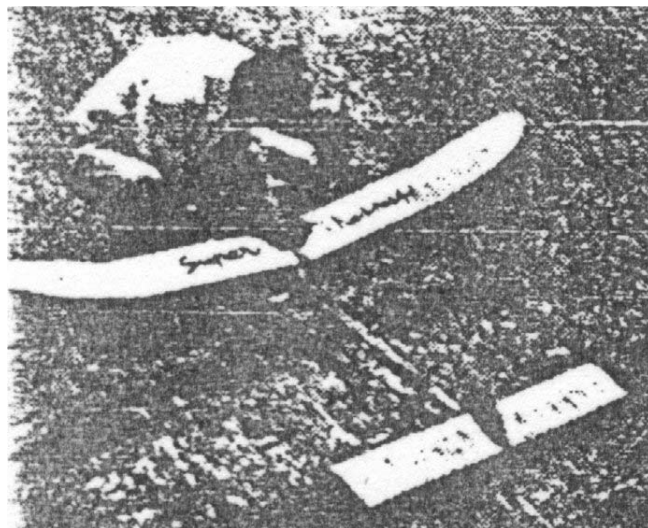

Designer Max Nicol prepares Super Thermic (plans opposite) for one of his winning flights at Bendigo.



The Class II and III free flight place-getters (L-R) at the 7th Nationals at Bendigo were W. Malcolm (2nd) Max Nicoll (1st) and A Coppock (3rd).

When test gliding, adjust the tailplane incidence until the glide just borders on the stall. A very slight amount of left rudder should be used to give a wide left turn. From then on, all power flight adjustments are made by varying the thrust line. Down-thrust is built in, and a little right thrust offset should be used to produce a right turn on the climb. Using this trim, the left rudder serves to hold the nose up, and prevent any spiral diving tendencies. Keep the motor run down to about five seconds at first; as you gain confidence this may be increased to ten or twelve seconds which should be quite sufficient to take your model up to the thermal regions. After that, Super Thermic's sailplane glide will do the rest.

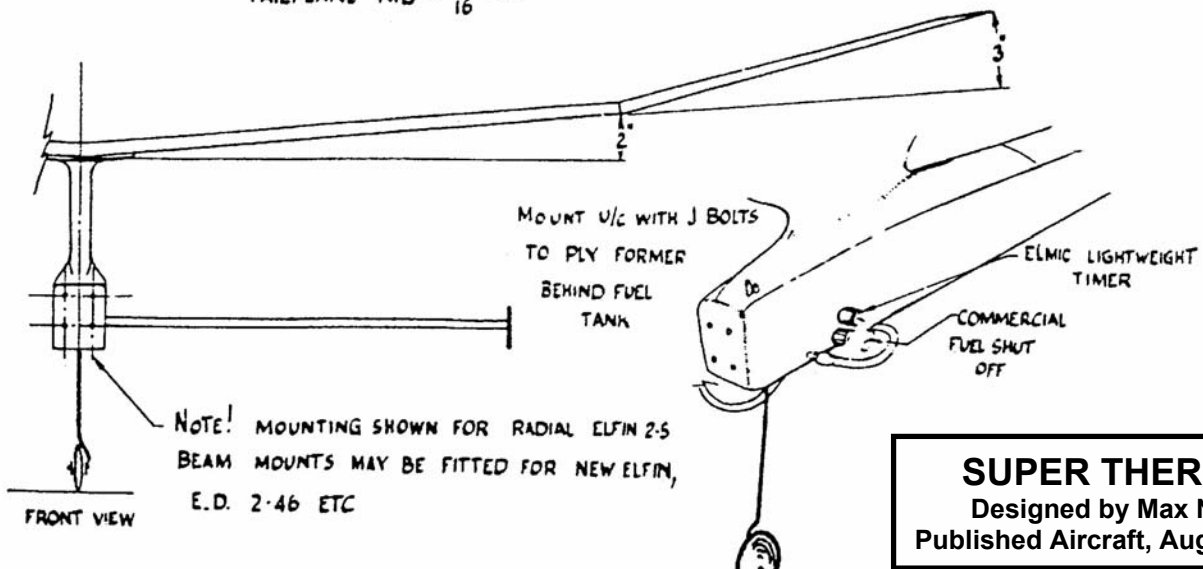
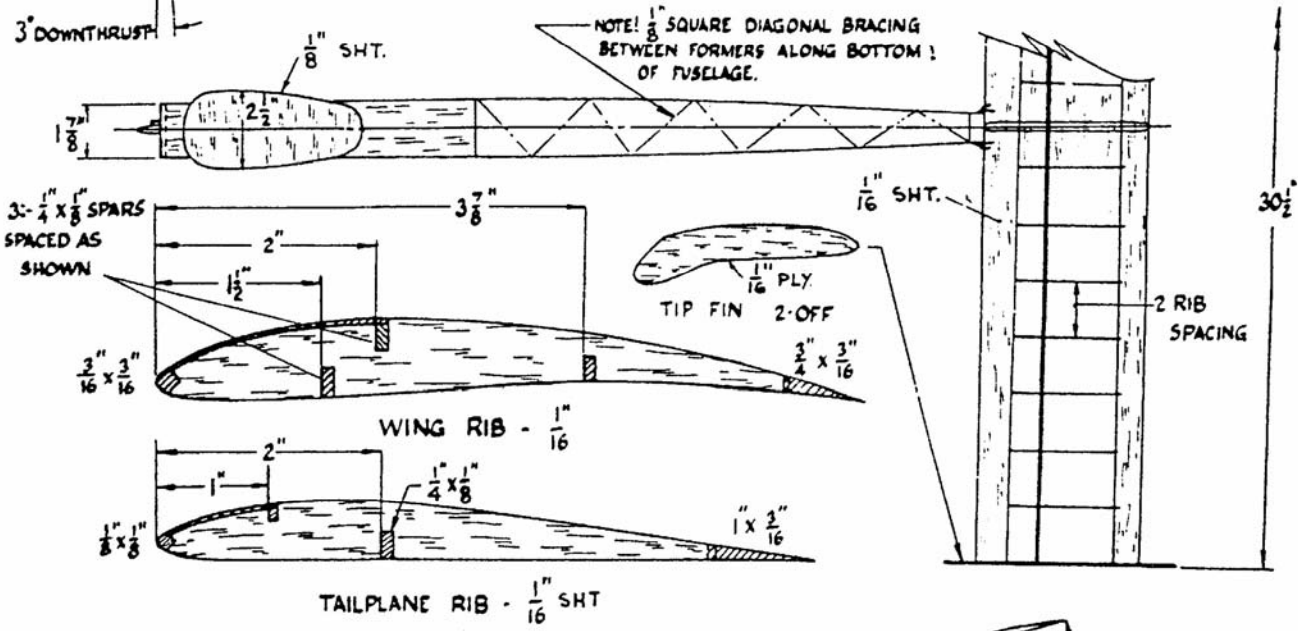
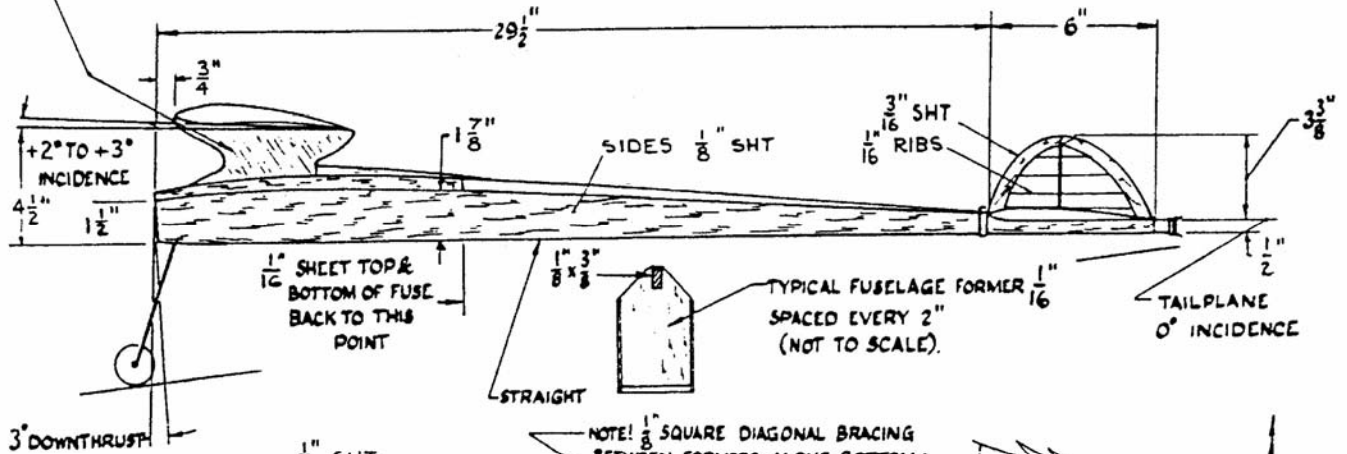
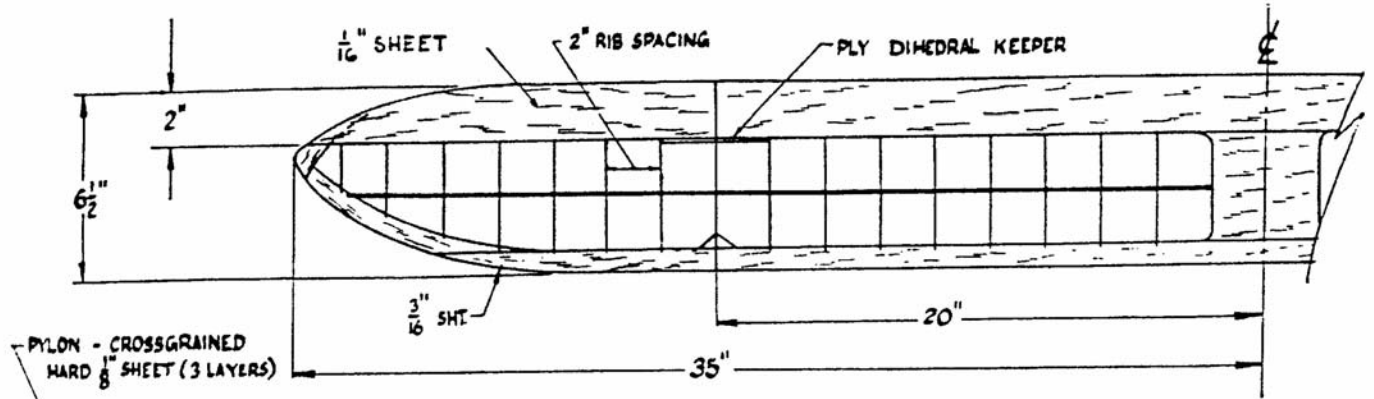

SUPER THERMIC
Designed by Max Nicol
Published Aircraft, August 1953

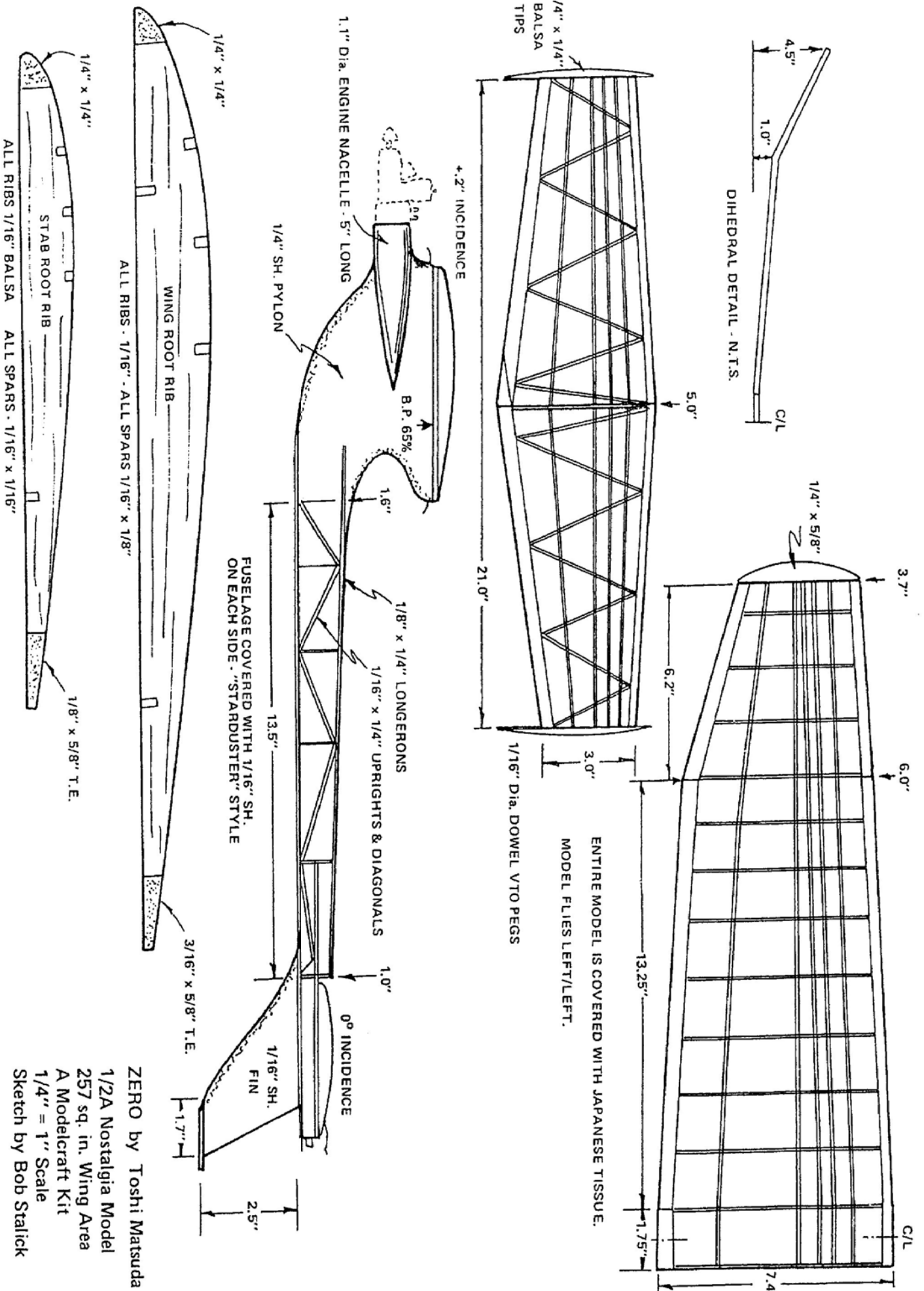

ZERO by Toshi Matsuda
 1/2A Nostalgia Model
 257 sq. in. Wing Area
 A Modelcraft Kit
 1/4" = 1" Scale
 Sketch by Bob Stalick

BITS 'n' PIECES

1/2A Texaco Tinkering

An article has been circulating lately about the care and feeding of Cox 1/2A Texaco engines. It was written by Norm Rosenstock several years ago and contains some good advice. However nothing in the original article mentioned the importance of filtering the fuel for those little rascals. Bill Schmidt is a strong advocate of fuel filtering, even each time you go to the flying field. So do it. Put a coffee filter in a funnel and then add two folded Kleenexes. Pour the fuel through this slowly, and I betcha you will have a happier Cox. The article did mention the problem with exhaust gunk being sucked into the air intake and hampering the running efficiency. Marcy Martin has this to say: "Regarding that article about Texaco O49's sucking exhaust residue into the air intake, the solution offered, the use of spacers behind the engine, would only compound the problem. Without the spacers the exhaust residue must pass over the top of the engine then down the sides and back up to the intake. With the spacers the residue goes right over the top of the engine a straight down to the intake, a much easier path. Thousands of O49's have been run without spacers. I would suggest that the author had some other situation that was relieved by spacers." Another clue for a happy O49. How many of us have examined the screen of the air intake on back of the engine? If clogged it will restrict the air supply.

Published in the March/April 2004 issue of "High Flight," the newsletter of the Sooner Antique Modelers of Tulsa, Oklahoma, Dan Hodges, Editor.

Tomby Trimming - from Mike Myers, SAM USA President. <balsabasher@yahoo.com>

Ned Nevels writes that he's got no excuse now not to finish his 44 inch Tomboy with a MP Jet Classic diesel in it. He expressed some worry about trimming it to fly FF. For what it's worth, here's my experience with trimming Tomboys. I've built and flown maybe 8 or 9 of them now (not counting Tomboys that friends let me fly). I've had difficulties trimming just one of them, but it was a bear.

First things first, get the CG at around 60-65% back from the LE of the wing. That's where RC guys get surprised, because they see the CG as waaay back of where it belongs. Hand glide it first and either raise the LE of the wing or the TE of the stab until you've got a nice floating glide with a gentle push from shoulder height. I hand glide mine with everything on the ship, but usually take the propeller off for the glide tests. If the airplane falls off to one side or the other in the hand glide, check for warps on the TE of the wing. Wing tips should have equal amounts of washout, but so long as they're equal, the Tomboy doesn't seem to be fussy about how much. You have to get this done first. I skipped this step with my last Tomboy, and had more trimming problems than I needed (or had had before) as a result.

Once you've got a straight level glide, start the Mills or the Class Jet .40 up and get it running at low power. (I've gotten away with launching at full power on the first powered flight, but don't recommend it. Tomboys are exceptionally forgiving, but not all of them take to the Bud Romak "Fly or Die on the First Flight" approach to trimming.)

I've had Tomboys that climb in circles to the right and Tomboys that climb in circles to the left. Vic Smeed's original Tomboy plan shows a hinged "rudder tab" at the top of the vertical fin. It's there for a reason. I leave it set to "straight ahead" for the first power flights. I want to see whether that particular Tomboy has a natural tendency to go either to the right or to the left. If you're happy with the amount of turn, increase power and trim fly again. If the turn is either too tight or not tight enough for you, move the rudder tab as appropriate to change the turn. Once you're happy, leave it there. Crank up the motor to full power (although at this point you may want to run on a partial tank) fire it up and go aviate.

I should say that about 2/3 of the Tomboys I've built were ultimately willing to be trimmed to fly in either direction. I could go right or left as I chose. The point of all this is that the Tomboy is an easy model to fly and trim.

As for choosing between the 36 inch wing and the 44 inch wing, I've built both. I suppose you may get a better glide with the bigger wing, but I've always been happy with whatever the Tomboy I had with me was doing. It's a sport flyer after all. When I was chasing the Australians in the annual Hilda Baker Postal Cup (for several years the Aussies always seemed to find a way to get a one hour plus flight on a Tomboy) I'd routinely get at least one five or six minute flight on a 3 cc tank when I was out flying. I increased the fuel tank size to about 6 ccs and my best flight time observed all the way to the ground was slightly over 16 minutes one year. That was good enough to win the postal that year. Guess the Aussies had an off day at the paddock that year.

SAM 270 - WESTERN AUSTRALIAN REPORT

From Paul Baartz.

SAM 270 Half A Texaco 2007

The weather was absolutely brilliant, cool and almost no wind with sunny skies. Entrant numbers were down a bit on previous events but those that did participate enjoyed the perfect conditions, some including John Taylor and Ray Sherburn did not enjoy the challenge set by the Cox engines however. Try as they might neither could coax a reasonable reliable engine run from these engineering marvels and both finished the day disappointed.

The contest started on time and all managed to complete their flights well within the two hour time limit. For the uninitiated this event comprises four flights of a six minute maximum with the best three to count as the score. A fly-off is conducted to determine placings between those achieving the three maximum flights.

Rick Rumball suffered a radio problem on his new Kerswap and decided to fly his old reliable RC-1 instead. Ray Sherburn eventually got the engine running only to damage the rear of his bomber in a hard landing and gracefully retired.

Only two made the fly-off which was a bit surprising considering the conditions and unfortunately Rob Rowson suffered a short engine run in the fly-off which minimised his time and winning chances.

½A Texaco Results:

1. Paul Baartz	55%RC-1	1080 + 270
2. Rob Rowson	50% Dallaire	1080 + 180
3. Rick Rumball	55%RC-1	1000
4. Ian Dixon	50% Bomber	973
5. Richard Sutherland	55%RC-1	941
6. Kevin Hooper	Brigadeer	712
7. Ray Sherburn	50%Bomber	161
8. John Taylor	50%Bomber	112

Standard Duration Results:

1. Paul Baartz	Playboy	1080
2. Alan Trott	85% Bomber	1054
3. Ray Sherburn	Playboy	1054
4. Rod McDonald	166% Kerswap	989
5. Ian Dixon	Thermal Thumber	921
6. Les Isitt	85% Bomber	845
7. Rick Rumball	Super Quaker	793
8. Rob Rowson	Playboy	766
9. Gary Dickens	Playboy	759
10. Andrew Isitt	Schmaedig Stick	703
11. Peter White	So-Long	698
12. Mark Sherburn	Playboy	533

WA State Championships Old Timer Standard Duration 2007

This event was held at KAMS field in Mundijong on Sunday the 12th August.

The weather Gods were smiling and the conditions were near perfect being fine with minimal clouds and a light easterly breeze which strengthened and got colder during the contest which made maxes a challenge, but were not enough to be uncomfortable.

Twelve entered and all flew with a few suffering problems ranging including a faulty carburetor needle to a wing "clapping hands" in mid-flight. Alan Trott, a veteran with a well tried model, had this inexplicable happening occur to his Bomber and won the splashdown of the day prize as the fuselage plummeted to earth in a particularly swampy area.

As stated maxes became harder to achieve as the contest progressed and the result of this was that only one flier qualified for the fly-off with the necessary three maxes.

The increasing wind also lead to a few landings outside of the designated area, which reduced good flight, scores to zero.

All entrants used the trusty OS Max-H .40 engines and apart from Rob Rowson whose carburetor needle went faulty, no major engine problems were experienced.

It rarely occurs apart from perfect scores with maxes, but Alan Trott and Ray Sherburn tied for second place and the result was determined by a count-back.

At the presentation of trophy and medals Glenn Milliken who managed the score sheet all contest, thanked KAMS for allowing us to use their field for the contest, and in particular Ian Dixon who arranged for this to occur.

GOULBURN OLDTIMER & GEOFF SHAW MEMORIAL TEXACO

4-5 May, 2007.

Saturday, although sunny, was windy and got stronger as the day wore on resulting in abandoning the Duration event. Sunday, a little windy to start with but developed into a very pleasant day which was particularly enjoyed by the Texaco fliers. A get together on Saturday night at the Services Club was enjoyed by all. Thanks to Paul Marshall for his excellent efforts as usual in organizing an enjoyable weekend.

Results:

Gordon Burford Event.

- 1. Jim Rae Internationalist/BR 870
- 2. Peter Scott Zoot Suit/PB 855
- 3. Paul Farthing P'Bomber/PB 811

1/2A Texaco.

- 1. Darren Marshall L'Diamond 1080 1075
- 2. Grant Manwaring L'Diamond 1080 1054
- 3. Jim Rae Pixy 1080 417
- 4. Tom Tobin L'Diamond 1080 250
- 5. Robert Smith L'Diamond 1080
- 6. Ian Avery P'boy Cabin 1061
- 7. Mark Nelson 830
- 8. Don Southwell Starduster 248

Geoff Shaw Memorial Texaco.

- 1. Don Southwell Bomber/OS41FS 1800 2393
- 2. Gavin Marshall Bomber/OS61FS 1800 2364
- 3. Paul Farthing Bomber/OS60FS 1800 763
- 4. Grant Manwaring Bomber/OS60FS 1800 744
- 5. Chris Chalker L'Stick/Marden60spark 1800 269
- 6. Tom Tobin 92%Bomber/OS48FS 1764
- 7. Jim Rae 75%Dallaire/Enya30FS 1604
- 8. Graham Parkins RecordBreaker/OS61FS 1539
- 9. Alan Wooding L'Stick/A'Spitfire spark 1500
- 10. Mark Nelson Scram/Magnum52FS 640
- 11. Mike Masters Bomber/Enya53FS DNF

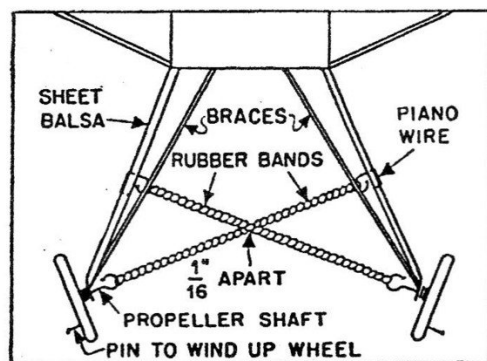
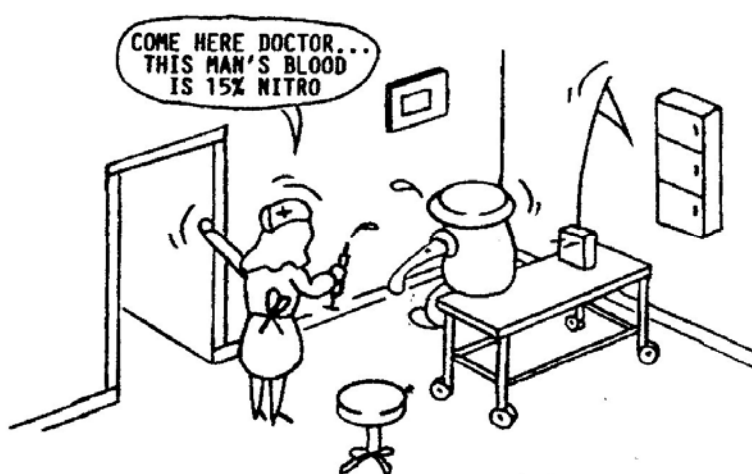

Before the model is released, the wheels are wound up with equal tension on the two rubber bands. The machine is then set on the ground in preparation for a take-off. Upon being released, the rubber bands are supposed to drive the wheels and accelerate the plane quickly into flight.

The above is from February 1935 *Universal Model Airplane News*. Paging Mr. Ripley!

Electric Old Timer - Progress with 1/2A Texaco From Lou Amadio.

The fastest growing sector in Electric Old Timer competitions is 1/2A Texaco with around 7 pilots now competing. Recently, Illawarra members ordered seven Stardust Special kits from Dave Brown so more to come!

Electric 1/2A Texaco models have been flown in the AEFA (Australian Electric Flight Association) Postal Competition for a few months now and a lot has been learned about the models and the electrics. As with most forms of competition, it is important to match the airframe to the power system.

The rules for Electric 1/2A Texaco are based on the SAM rules except for the power system and the flight duration. There is also a maximum wing area rule of 400 sq in. Models are allowed 5.05 watt.hours of battery energy and must fly for 15 minutes to complete the task. See the rules at: http://www.maaa.asn.au/electric/rules/nefr_rg.htm

Why 5.05 watt.hours?

Texaco models are regulated by an energy rule analogous to a fuel allocation for an IC(gas) model. When we developed the power systems around 12 months ago using a typical 1/2A model (Playboy Senior, 373 sq in wing area) the smallest battery pack that would allow the model to climb to thermal height in a reasonable time (~2 min) was a 7 cell 600mAHr NiCad pack. Therefore, 7cells x 0.6Ahr x 1.2v = 5.04 watt.hours).



Stan Clifton proudly shows off his new Electric Stardust Special after trimming to fly in 1/2A Texaco. Power system consists of a BM2410-12 brushless outrunner from LSE swinging an 8x4.7 APC slow-fly prop. This combo, which includes an 18A ESC, is a very cost effective power system for this type of model. Battery is a 3 cell Hyperion 400mAHr pack with a 20C rating which means it can sustain 8A. Wing area is 395sq in and AUW is 510g. Flies like an angel!

Why a 15 minute task?

Field tests showed that the 7 cell Ni pack above could fly a model for around 11 minutes in still air before the BEC cut the motor. In order to ensure that the task could NOT be completed without thermal assistance, a time of 15 min was set. With postal experience over the last few months this time is certainly not excessive!

What battery pack can be used?

As long as the total battery pack energy is no more than 5.05 watt.hours, then any number or type of cell is allowed. This gives competitors some flexibility in choosing a power system.

$$\text{Max cell capacity (Ahr)} = 5.05/\text{cell count}/\text{cell voltage}$$

Example 1, for a 3 cell LiPo pack: Capacity = 5.05/3/3.6 = 0.468 Ahr or 468 mAHr max.

Example 2, for a 2 cell LiPo pack: Capacity = 5.05/2/3.6 = 0.701 Ahr or 701 mAHr max.

When using the formula, Ni cells have a nominal voltage of 1.2v and a LiPo cells 3.6v. Other battery pack combinations might include 6 x 700 mAHr Ni cells or 8 x 500 mAHr Ni cells as these also fall within the 5.05 watt.hours energy rule.

What electric motor is suitable?

Any motor weighing between 50-80g is suitable for these small models providing it is matched to the battery and propeller. The maximum current is generally determined by the battery pack and is around 8-10A for this type of competition. The motor Kv (RPM/volt) is determined by the battery voltage. Props currently in use are 8"x4" or 9"x4" or 9"x6", chosen to keep the current under 10A.

Option 1: a motor Kv of 1500 would suit a 2 cell LiPo or 6 cell Ni pack.

Option 2: a motor Kv of 1000 would suit a 3 cell LiPo or 8 cell Ni pack.

Please note that the Kv ratings are at the propeller. If a gearbox is used, the motor Kv will be higher and directly proportional to the gear reduction.

63% ELECTRIC CUMULUS - WING SPAN = 60.5"

- Wing Area=452 in²
- Flying weight=35.7 oz
- Motor : Hacker B40 10S+4.4:1
- Prop : APC 12x8E
- Cells : (7) N-800AR
- Duration = 8.0 min.
- 60 sec. Motor Run Time
- Rate of Climb = 1191 ft/min
- Event : SAM Electric LMR Class A

The Class A Electric LMR event utilises the proposed 60 seconds motor run time and can achieve the required 7 minutes. As shown below it is a 63% Cumulus with a 452 sq.inch wing area.



LOOKING BACK..... Seventh National Meeting (1953-54)

With only five months left in the year, the thoughts of competitive modellers will be turning towards the next Nationals which are to be held in Queensland in the week following Xmas. The meeting which is being conducted under the auspices of the Model Aeronautical Association of Australia, will include all the usual events for Free Flight, Gliders, Flying Scale, Radio Control, Speed, Team Speed, Stunt, Payload, etc., and in addition two former events have been re-instated by popular request, namely Class "C" Team Speed and FAI Sailplanes.

One new event to be seen for the first time will be control line combat. In this, two or three models are flown in the one circle trailing long streamers. A violent free-for-all ensues, and the survivor landing with the longest streamer is the winner. This event is becoming very popular, and should prove a real thriller at the Nationals. Another point worthy of note is that the Wakefield event will serve to pick the team to represent Australia in the 1954 International Wakefield.

Some of the Victorian contingent are planning to charter a bus for the return trip to Brisbane, and anyone interested is requested to get in touch with Max Nicol, 4 Brighton St., Preston, as soon as possible. *(from AIRCRAFT Magazine, August, 1953)*

O&R TUNING TIP #20 - ERRANT CAM GRIND:

By Abe Gallas/Bob Angel.

Abe Gallas passed this along while we chatted at the SAM booth at AMA's Pasadena trade show. Abe was trying to start a newly acquired O&R, and the prop kept biting his fingers. He first assumed the O&R was just in a bad mood, but after a while he found that the normal retarded spark setting was still too advanced. And at full retard, it was still too far advanced. This happened some time ago while both Otto Bernhardt and Irwin Ohlsson were still with us. Abe took his engine to Otto, who fixed it by opening up the front bushing slot some more to allow more retard.

Abe later learned through Irwin Ohlsson that a few cams had been improperly ground because of wear or slippage of the fixture used to position the crankshaft. These cranks were set aside, but the glow model O&R's were just coming out. There was no point in wasting otherwise good cranks, so they were put into some of the glo's, which wouldn't be using the cam anyway. Who could imagine that some of us would ever be going backwards by converting glow models back to spark ignition?

So when you acquire a glow O&R and find to your satisfaction that the crank has a cam ground on it, you might not be in hog heaven just yet. The odds are low, but you just might have one with the cam ground too advanced. If that should happen and you have the means to do so, it would probably be better to extend the cam grind rather than cut away more of the front bushing. That would give a little more dwell for high speed running, and would leave more bearing support and a smaller entry for field grit. The timer arm would then work in the same familiar area as other Ohlssons. Plus, the little "stops" provided where the longer timer retaining screw contacts case ribs, would still be usable.

JOHN POND

P.O. JOHN POND O/T PLAN SERVICE 156
 253 NORTH 4TH STREET
 P. O. BOX 90310
 SAN JOSE, CA 95109-3310

13 January 1995

HOME John I. Pond
 4269 Sayoko Circle
 San Jose, CA 95136

IAN
 Rear Avery:

WAS RUMMAGING THROUGH SOME OF MY
 OLD CORRESPONDENCE AND RAN ACROSS THE
 ENCLOSED ARTICLE I HAD WRITTEN FOR MODEL
 BUILDER & MY "PLUG SPARKS" COLUMN.

FOR SOME UNGOODLY/REASON THE EDITOR,
 PHIL BERNHARDT, REJECTED THIS PORTION SAYING
 THEY DIDN'T HAVE CONTROLINE IN THE O/T
 PERIOD, I POINTED OUT THE ERRORS OF HIS
 THINKING IN THAT CONTROLINE HAS BEEN WITH
 US FOR SINCE 1939.

ANYWAY, I THOUGHT YOU COULD USE
 THE MATERIAL IN ONE OF YOUR FUTURE ISSUES,
 YOU NEVER KNOW WHEN YOU WILL RUN SHORT
 (VOICE OF EXPERIENCE!)

Hope this finds you fully recovered
 from the holiday season

Regards
 John

MODEL OF THE MONTH

From John Pond.

When the $\frac{1}{2}$ A engine craze first broke
 out in free flight, resulting in a tre-
 mendous amount of entries, it was only
 natural the boys would try the .049
 size engines in controline.

To meet the immediate demand, most
 kit manufacturers, Berkeley, Veco, Sci-
 entific, Megow, etc. converted their
 standard large controline designs such
 as Zilch, Warrior into models such as
 the Mini-Zilch, Veco Scout, and a host
 of designs. Here was something that
 the young modeler could literally fly in
 his own backyard.

Needless to say, the hobby dealers'
 major income was derived from these
 easy to build, attractive looking models.
 The cost of acquiring engines, kits, ac-
 cessories, etc. was markedly lower than
 that required to fly the big 35 to 60
 powered stunt models.

This was later proven by Cox Mfg. Co.,
 when they developed plastic scale con-
 troline models powered by their small
 engines. Inasmuch as these type mod-
 els were aimed at the department
 store trade, literally hundreds of thou-
 sands of these type $\frac{1}{2}$ A controline mod-
 els were sold.

For this month's drawing of the Veco Scout, we are indebted to Joe W. Wagner, who was working for VECO at that time developing kits which, to this date, are still being produced by Dumas, the successor to Veco. This Joe Wagner is not to be confused with the Eastern Joe Wagner, who marketed the Bantam and the Morton Five Cylinder engines.

Joe W. Wagner founded the MECA as part of his activities in engines being used in controline flying. With his background, he was the "guru" for many years and is still regarded as the leading engine authority. With this background, it was a natural he would make up the drawings of the Veco line and select a suitable engine to power the design. No question about it, the Veco line of stunters was unsurpassed and have proved this point over the last fifteen years.

Bully at the Bar

There's this guy in a bar, just looking at his drink. He stays like that for a half-hour. Then, this bully steps up to the bar, takes the guy's drink, and just drinks it all down.

The poor man starts crying. The bully says: "Oh, come on, man! I was just joking. Here, I'll buy you another drink. I can't stand to see a man crying."

The troubled fellow replies, "This day is the worst of my life. First, I get fired for oversleeping and getting to work late. Then, as I'm leaving the building, I find out my car was stolen. I get in a cab to return home and I forget my wallet and credit cards in the cab. Then, I find my wife in bed with the gardener.

So I end up at this bar, and just when I was thinking about putting an end to my life, you show up and drink my poison."

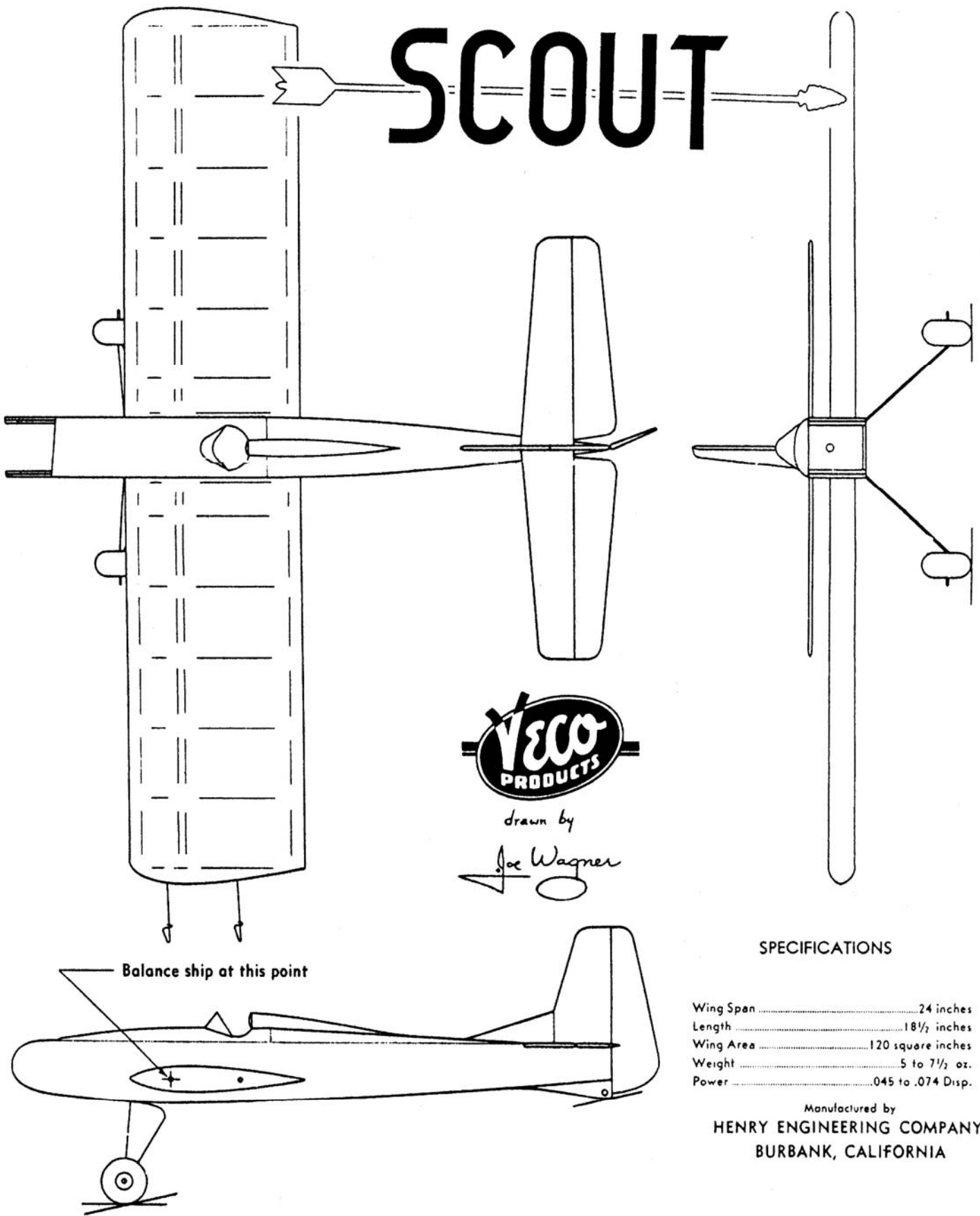

SCOUT



drawn by
Joe Wagner

SPECIFICATIONS

Wing Span	24 inches
Length	18½ inches
Wing Area	120 square inches
Weight	5 to 7½ oz.
Power045 to .074 Disp.

Manufactured by
HENRY ENGINEERING COMPANY
BURBANK, CALIFORNIA

CHEATING WIFE A man, returning home a day early from a business trip, got into a taxi at the airport. It was after midnight. While en-route to his home, he asked the cabby if he would be a witness. The man suspected his wife was having an affair and he intended to catch her in the act. For \$100, the cabby agreed. Quietly arriving at the house, the husband and cabby tiptoed into the bedroom. The husband switched on the lights, yanked the blanket back and there was his wife in bed with another man. The husband put a gun to the naked man's head. The wife shouted, "Don't do it! This man has been very generous! I lied when I told you I inherited money. He paid for the Rolls Royce I bought for you. He paid for our new cabin cruiser. He paid for your SCC season tickets. He paid for our house at the beach. He paid for our country club membership, and he even pays the monthly dues!" Shaking his head from side-to-side the husband slowly lowered the gun. He looked over at the cab driver and said, "What would you do?" The cabby replied; "I'd cover him up with that blanket before he catches a cold."

WHAT DO THEY LOOK LIKE ?

The "HUMDINGER"

... by Scientific

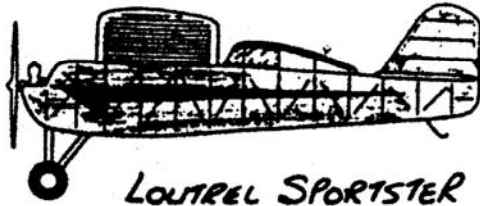

LOUREL SPORTSTER

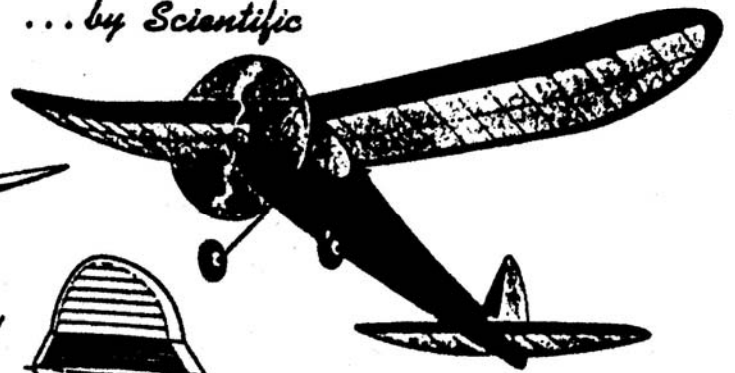

AIR WARDEN



GOLDBERG "SAILLANE"



WESTERNER



VAGABOND



Henry Struck's



POWERHOUSE

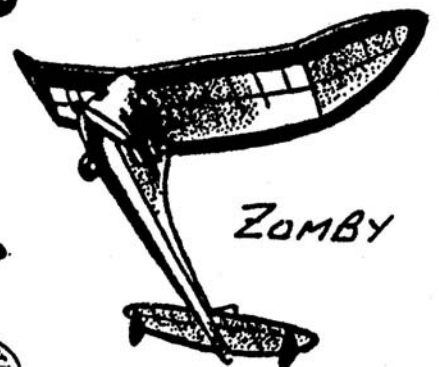

ZOMBY

SKYBUGGY



ARDENT "A"IR

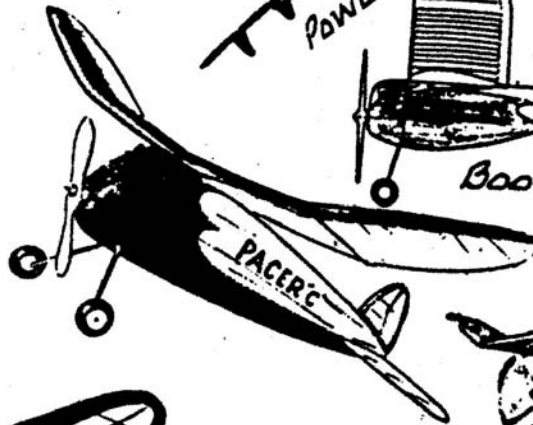

PACERC

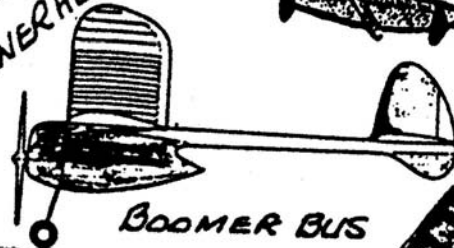

BOOMER BUS



ZOOMER

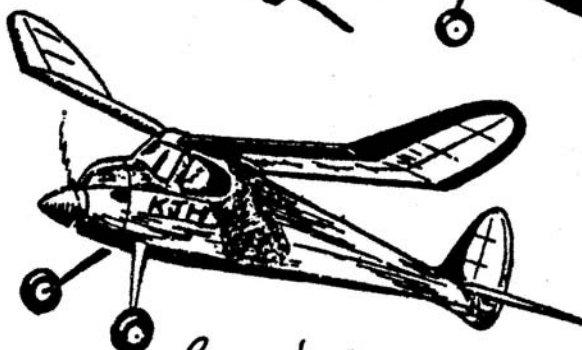

PLECAN'S SNOOTY



SADLER LOW WING PACEMAKER

MODEL KNIFE BLADE SHARPENERS

Sharpy. Edger guide with Arkansas slip.

From Joe Wagner

My diamond sharpening stone came with a small bottle of oil to prevent loading the surface. We sell diamond hones and stones in the retail store I work in, and always have a sample on the counter for customers to try out on their knives. It is always used with water as a lubricant. Dennis Karoleski in New Hampshire.

...Dennis, lubricating sharpening stones is generally good practice. It keeps the stone surface from getting clogged with metal particles, which can happen readily when sharpening stainless steel pocket knife blades. Those are extremely common today.

But I was speaking exclusively about sharpening X-Acto knife blades. Those are high-carbon steel, and have never shown any tendency to "load" my diamond stone when used dry. The ground-off metal just lies like a coat of dust on the surface, and can be blown away with an air hose or washed off with water.

I use my diamond stone dry for sharpening X-Acto blades because it's much more convenient that way. Before I got the diamond stone I used a regular oilstone for the same purpose. It worked great -- but was messy and slow. Before I could put the knife back to work I had to clean off the dark oily swarf from both the stone and the blade. Not with the diamond stone!

Four SMALLsters have requested further information on X-Acto blade-sharpening technique, so here it is:

The easiest way I can think of to describe how to sharpen a knife blade of any kind on any sort of whetstone -- oil, water, or my new favorite, the dry "diamond stone" -- is to apply the knife to the stone exactly as if you were trying to peel off a very thin shaving from its top surface.

You don't need any more pressure than it takes to hold the blade in contact. Excessive pressure is counter-productive! Take a stroke or two on one side of the cutting edge; then reverse the action and do another couple of "slicing passes" with the other side of the blade.

If you move the edge straight across the stone, as if you wanted to peel off a continuous layer as wide as the blade edge is long, doing that will abrade the blade edge fast; but will produce a microscopic "sawtooth edge". This isn't always bad -- I like that effect for cross-grain carving.

For a smoother cutting edge (one that will slice cleanly through model covering materials) move the blade edge at an angle across the stone rather than straight across. Use light pressure too.

But any kind of abrasive sharpening of a cutting edge will leave a burr. Imagine putting a cutting edge on an aluminum yardstick, with 40-grit floor-sander abrasive paper. The ragged edges of the abrasive particles not only plow metal particles away (which is what you want) -- they also deform the thin edges they leave behind.

Scale this picture down to #11 X-Acto knife blade size, and you can see the benefits of eliminating burrs from the edge. "Burnishing surfaces", such as an old-fashioned razor strop, can be used to polish off microscopic burrs and bring the actual cutting edge as close to one molecule thickness as possible.

Peck Polymers sells a neat small sharpening tool called, appropriately, a Sharpy. It has a fine abrasive surface on one side; the other is impregnated with jeweler's rouge for burnishing cutting edges. Quick Tech hobby is the new company website for Peck Polymer. The Sharpy is at:

http://www.quicktechhobby.com/Merchant2/merchant.mvc?Screen=PROD&Store_Code=QTH&Product_Code=PECPA8

The Sharpy works well; but somehow I can seldom find mine on my always-cluttered workbench top when I need it. (It always turns up later, though, when I DON'T need it.)

Instead I burnish my freshly-diamond-sharpened X-Acto blade edges on whatever's handy. The flat cast-iron top of my table saw works fine for that; so does the grey cardboard backing of a scratch pad. It really doesn't take much force or pressure to remove (or flatten) microscopic burrs on modeling knife edges. After all, they're only a few microns thick.

How can you tell when you've sharpened your knife enough? Easy: when it cuts whatever you want it to cut, the way you want to cut it. I've come across various suggested tests for knife-edge keenness, such as whether you can SEE the actual edge. (If so, it's still dull.) Another test is to try gently skidding the blade edge sideways when it's set vertically on your thumbnail. (If it skids, it's still dull.)

But to my way of thinking, the ONLY valid test is that of USE. If your blade will slice cleanly through Esaki tissue without tearing, or do whatever other modeling task you want to accomplish, it's SHARP. (If it won't, it's not.)

Plane buffs fly in for contest

For the fourth year the Dalby Model Aero Club hosted the State Championships of the Society of Antique Modellers, The Vintagents.

All model planes for the Vintagents championships are based on pre-December 31, 1941 plans.

The event was held at the Dalby Model Aero Club's field at "Taunton" on the Cecil Plains Road.

Twenty nine competitors contested six events.

The Col Borthwick trophy for Open Duration was won by Arnold Broese from the Sunshine Coast and the Open Texaco Competition was won by Basil Healy from the Central Coast in NSW.

Other events included the Gordon Burford, 1/2 A Texaco, Antique 38 (for planes designed before December 31, 1938) and the Dalby Climb and Glide.

Competitors came from as far north as Cairns and Townsville and as far south as Ballarat and Gippsland and many places in between including the Sunshine Coast, Toowoomba, Brisbane, Gold Coast, Singleton, Lithgow, Canowindra and Gosford.

Because of the wind on Saturday it was not possible to fly so Saturday's events had to be split between Sunday and Monday which put all events off schedule.

With good flying conditions on Sunday and Monday all events were eventually flown and the fly in finished around 4pm on Monday instead of lunch time.

On Monday one plane malfunctioned and got away expected never to be seen again.

The owner estimated that it had enough fuel and altitude to fly as far as Toowoomba.

About an hour or so later a motorist travelling on the Toowoomba Road noticed a model plane beside the road, retrieved it and contacted the club.

The plane had landed safely and was undamaged much to the relief of its owner.



Paul Farthing of Canowindra NSW launches his Pencil at the State Championships of the Vintagents at the Dalby Aero Club on Monday.



At the trophy presentation at the State Championships for the Society of Antique Modellers are Jim McCotter (Vintagents member and member of the Dalby Aero Club), Arnold Broese (winner of the Borthwick Trophy), Basil Healy (winner of the Open Texaco Competition) and Jim Hardy, secretary of Vintagents.

~ THE BACK PAGE ~